

SECTION 53AiS/U: DYNON ADS-B IN

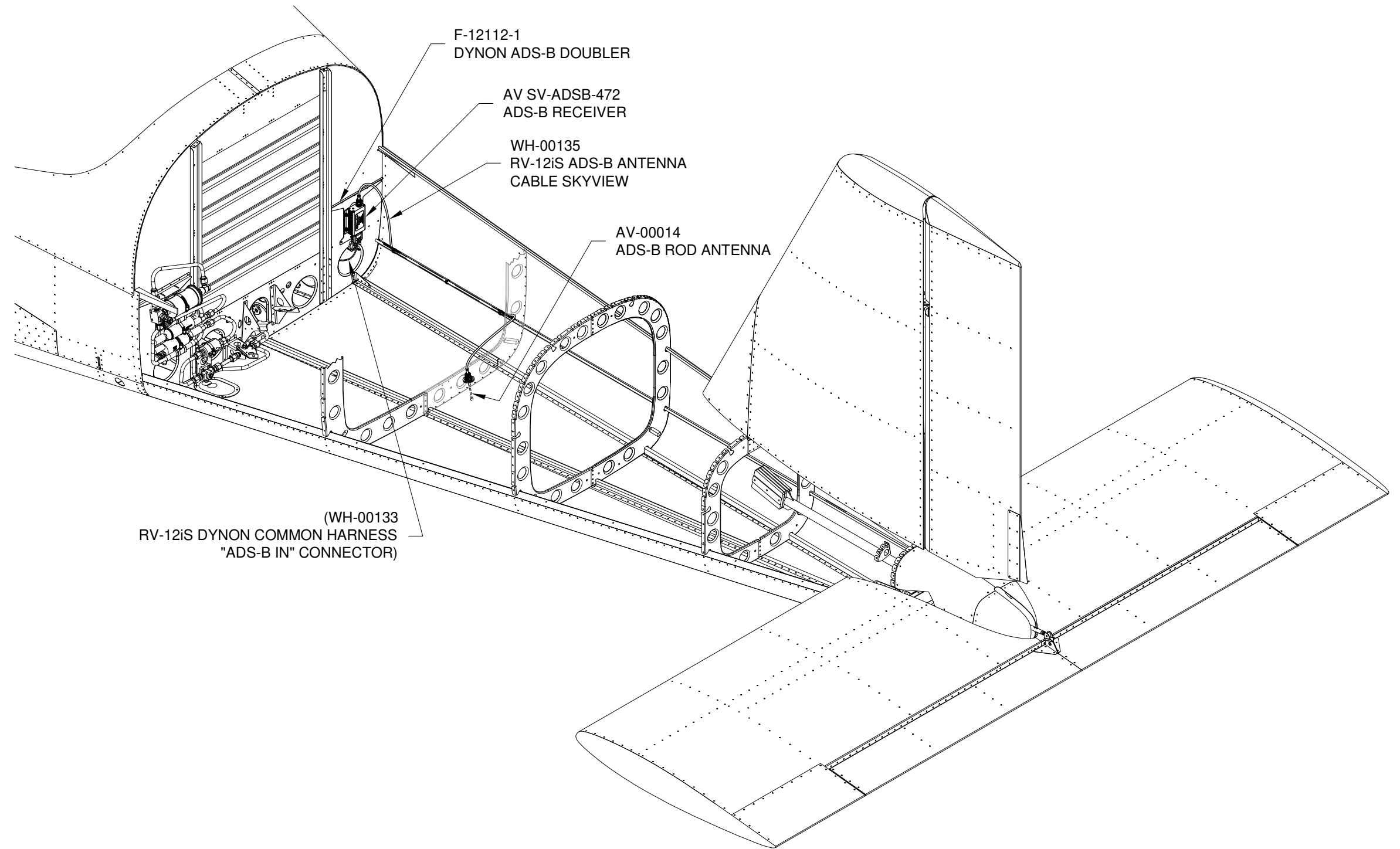



NOTE: Refer to Figure 1 for all steps on this page.

Step 1: Remove the three rivets on F-01207C-R-1 Baggage Bulkhead that will correspond to the lower portion of the F-12112-1 as shown.

Step 2: Cleco the F-12112-1 to the F-01207C-R-1 using the lower three holes. Match-Drill #30 the five upper holes from the F-12112-1 into the F-01207C-R-1 as shown.

Step 3: Final-Drill #27 the four attach holes for the AV SV-ADSB-472 into the F-01207C-R-1 as shown.

Step 4: Rivet the F-12112-1 to the F-01207C-R-1 as shown.

Step 5: If required, rivet the three holes in the F-01207C-R-1 as shown in Figure 2 (e.g. the one hole to the left and the two holes to the right of the F-12112-1).

Step 6: Attach the AV SV-ADSB-472 to the F-12112-1 with the hardware as shown.

Step 7: Locate the "ADS-B IN" connector on the WH-00133 and connect it to the AV SV-ADSB-472. Ensure that the WH-00133 does not hang down and contact the right flaperon torque tube.

Step 8: Step drill 1/2 a hole in the F-01282-R-1 Bottom Right Skin as shown in the detail view.

Step 9: Install the AV-00014 as shown in the detail view and connect the WH-00135 to the AV-00014.

Step 10: Route the WH-00135 forward along the stiffener in the F-1281-R Lower Skin and connect it to the AV SV-ADSB-472.

Step 11: Per the figure, secure the WH-00135 to the F-1281-R by inserting tie-wraps through the holes in the stiffener. Ensure that the WH-00135 does not contact the F-1208-R Fuselage Frame.

To prevent chafing, place two strips of F-1257B "cat track" (MS21266-1N) between the WH-00135 and the F-1281-R stiffener where the WH-00135 enters/exits the stiffener as shown.

Adhere the F-1257B to the stiffener using small amounts of RTV or fuel tank sealant.

END OF SECTION

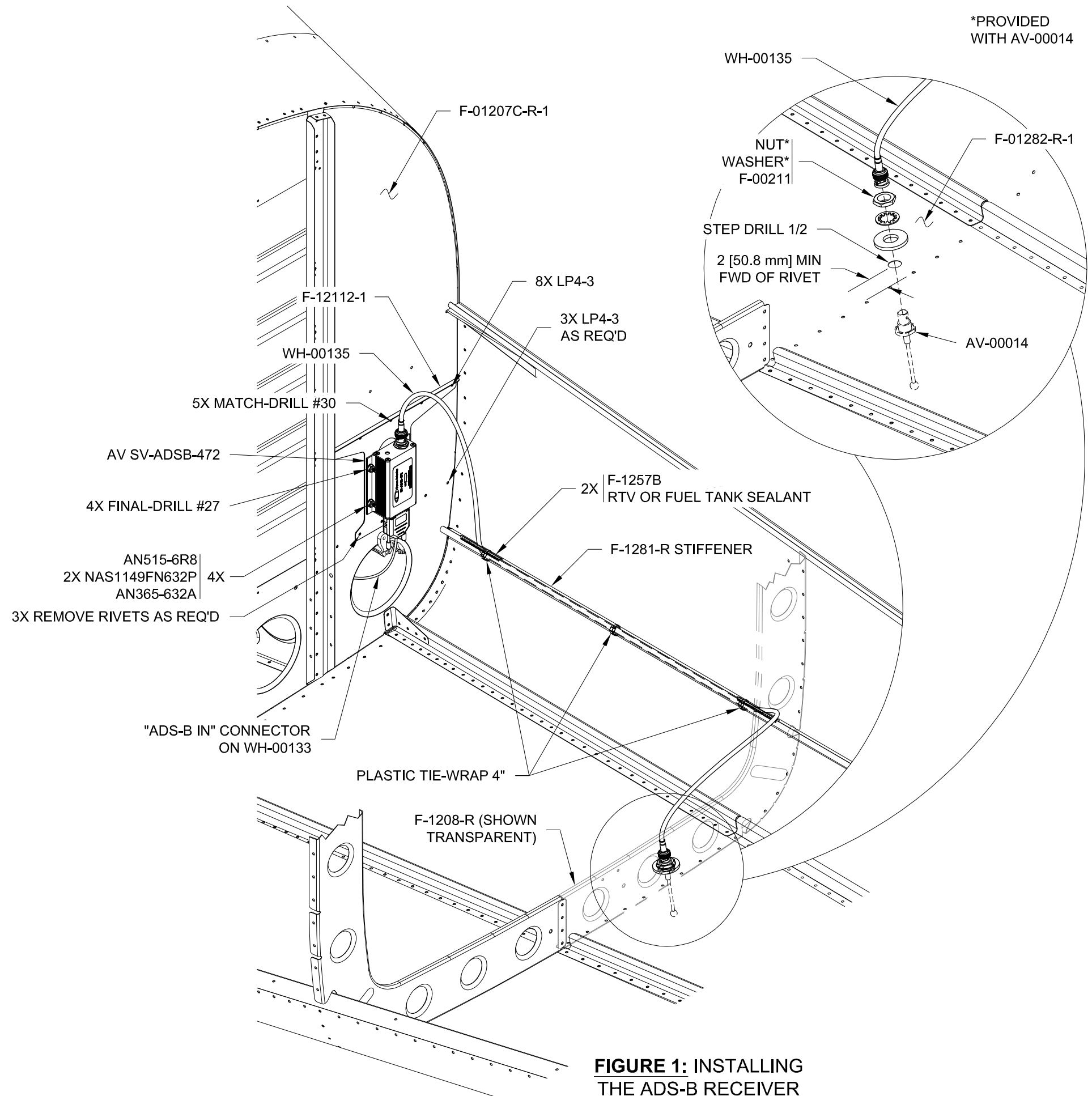

FIGURE 1: INSTALLING THE ADS-B RECEIVER