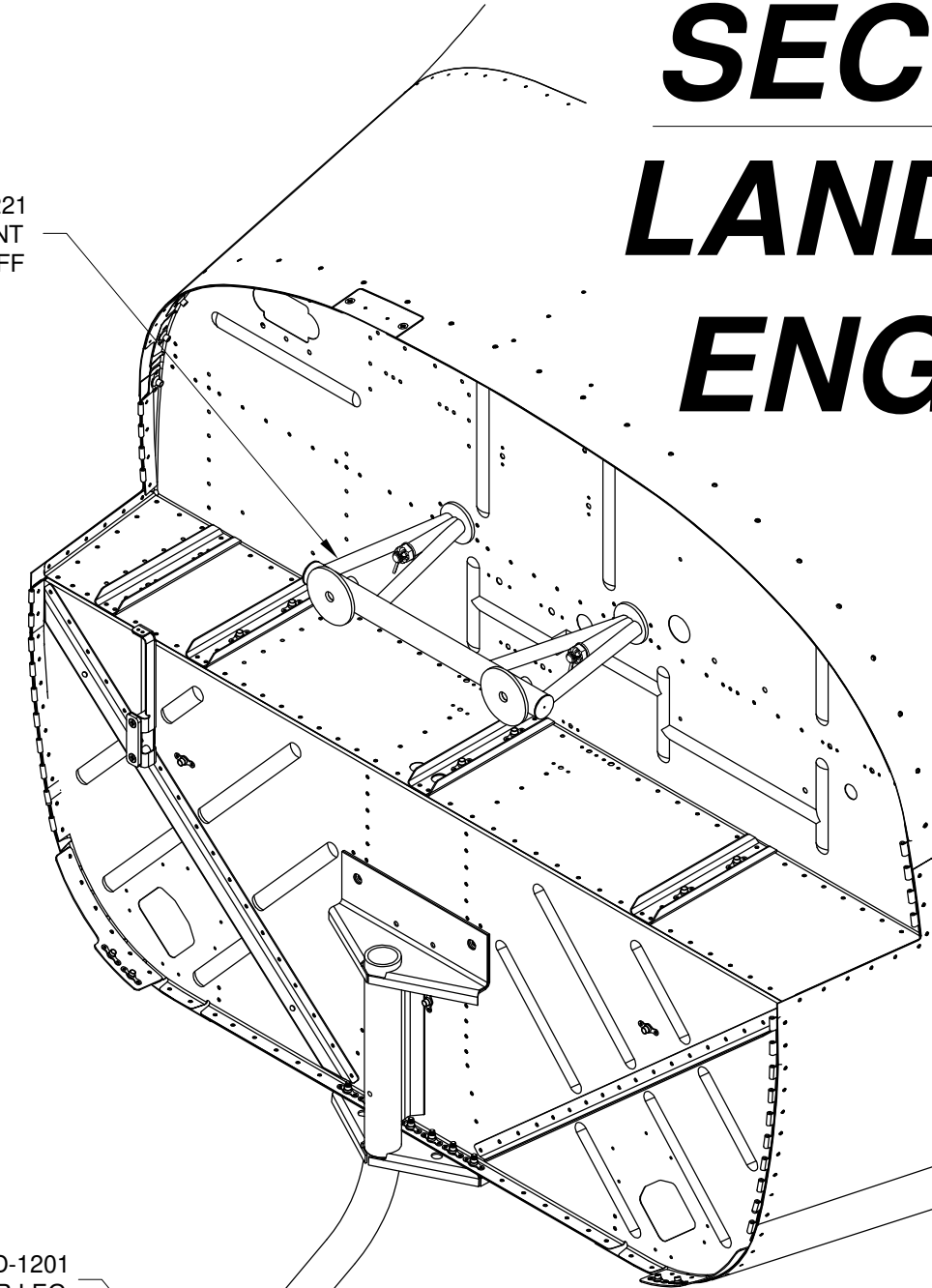


# SECTION 35iS/U: LANDING GEAR & ENGINE MOUNT

WD-1221  
ENGINE MOUNT  
STANDOFF



U-01203E-1  
INBOARD  
DOUBLER PLATE

U-01203B-1  
INBOARD  
WEAR PLATE

U-01202A,  
OUTBOARD  
WEAR PLATE

U-01220-L-1  
(U-1220-L SHOWN)  
MAIN LANDING  
GEAR LEG

U-01203C-1  
BEARING  
PLATE

U-01203-2  
(U-01203-1 SHOWN)  
INBOARD MAIN GEAR  
ATTACH BRACKET

U-01202-1  
OUTBOARD MAIN  
GEAR ATTACH BRACKET

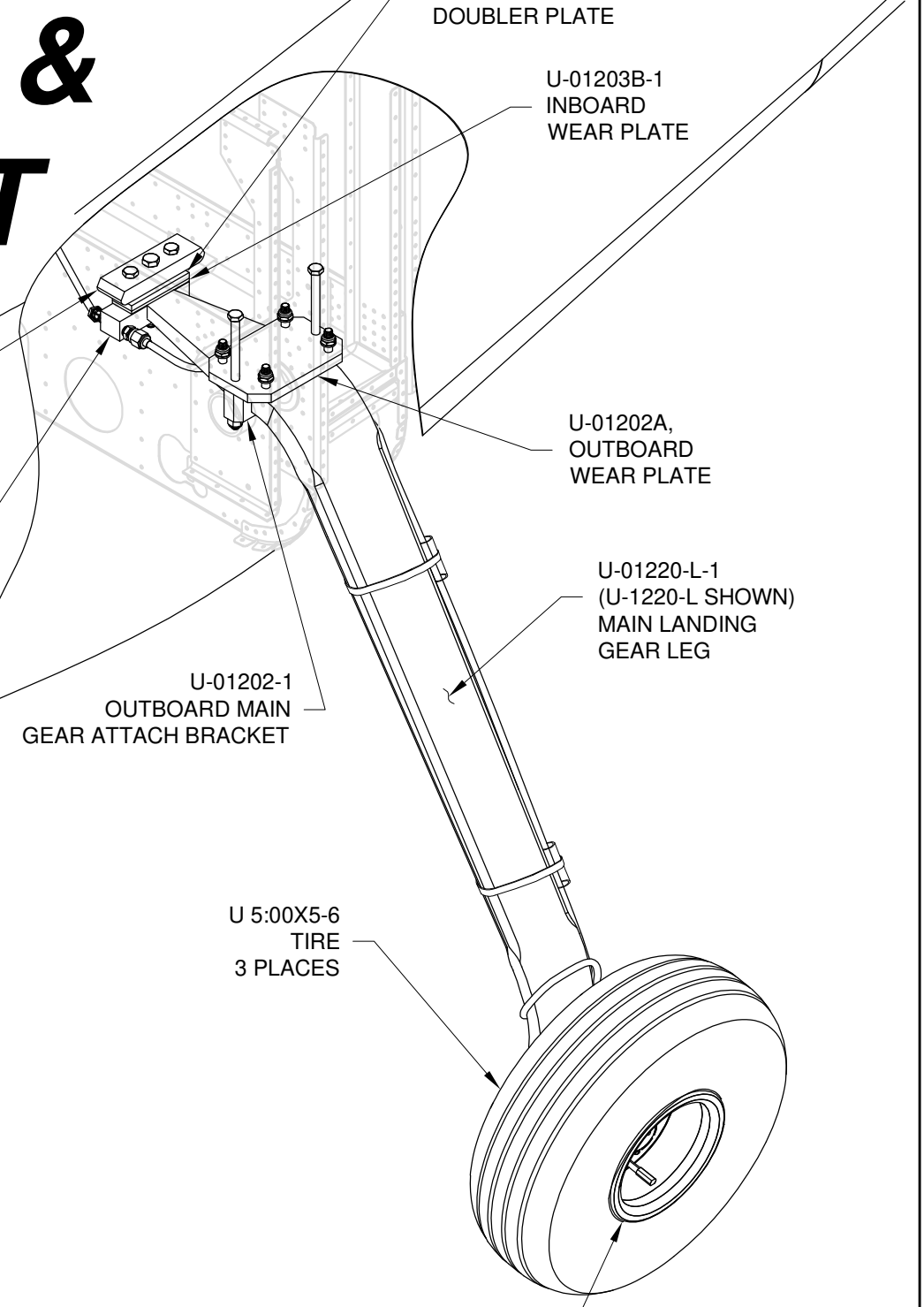
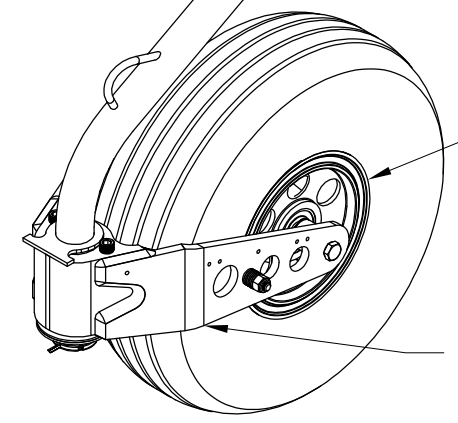
U 5:00X5-6  
TIRE  
3 PLACES

U-MHMHE51B 5" WHL/BRK  
WHL/BRK/AXL SET

WD-1201  
NOSE GEAR LEG

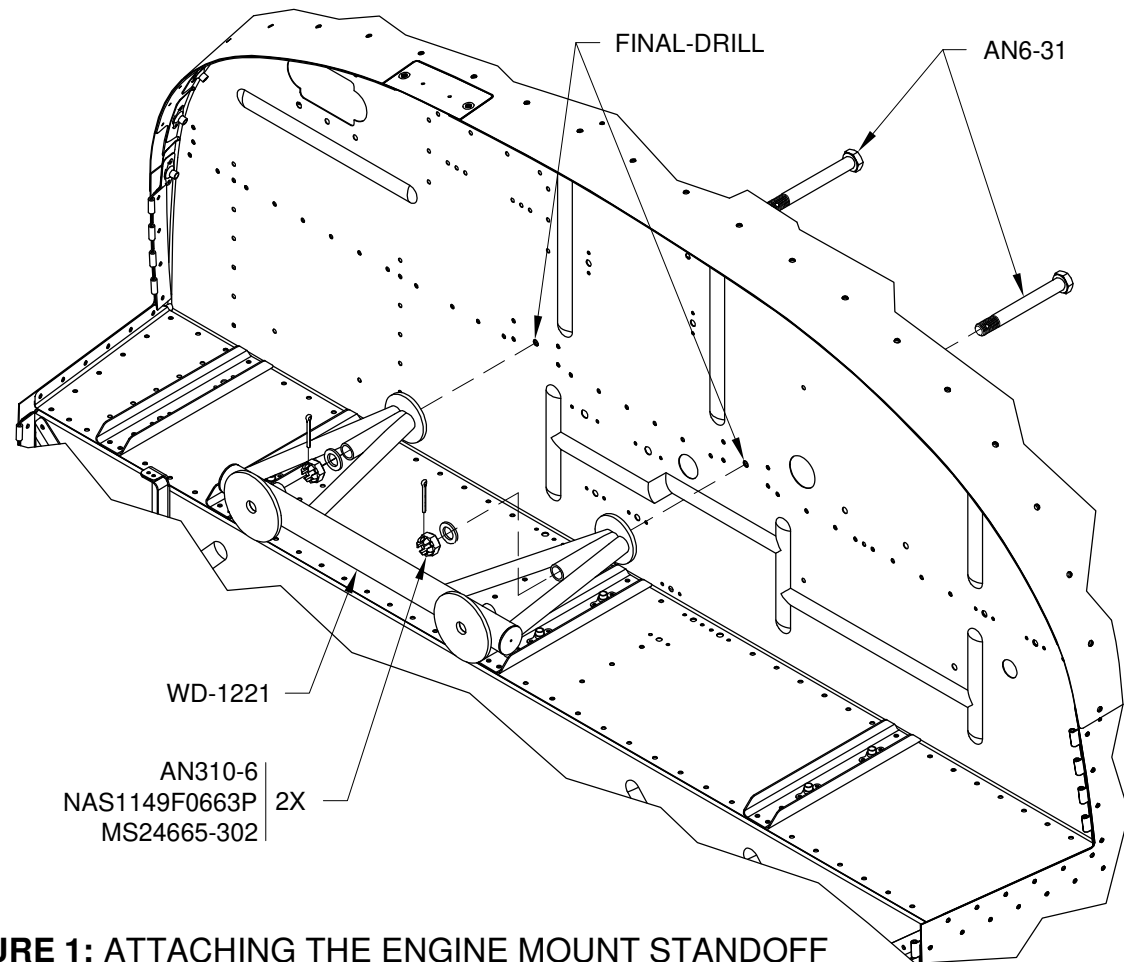
U WHLW51CCWHEEL  
NOSE WHEEL

WD-01230-1  
NOSE FORK



**Step 1:** Final-Drill 3/8, starting with a step-drill, the two .188 [4.8 mm] holes in the top of the Firewall Assembly common to the WD-1221 Engine Mount Standoff. Once the hole in the stainless sheet is 3/8 diameter switch to a 3/8 in. bit. Be sure to drill perpendicular to the vertical face of the Firewall Assembly. Deburr the holes in the Firewall Assembly.

**Step 2:** Permanently bolt the engine mount standoff to the Firewall Assembly using the hardware called out in Figure 1. If the bolt holes do not align, up to 1/32 in. [.8 mm] may be filed from edges of holes to allow bolts to pass through the Firewall Assembly and into the standoff.



**FIGURE 1: ATTACHING THE ENGINE MOUNT STANDOFF**  
(SOME PARTS OMITTED FOR CLARITY)

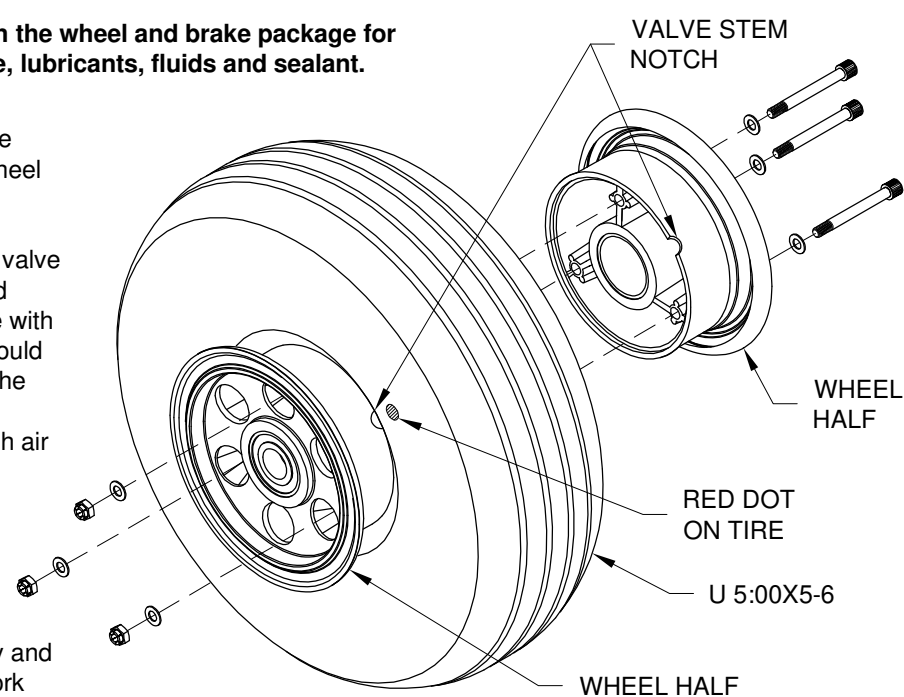
**NOTE:** See the documentation included with the wheel and brake package for helpful assembly tips, recommended torque, lubricants, fluids and sealant.

**Step 3:** Split the U WHLNW51CCWHEEL Nose Wheel by removing the bolts holding the two wheel halves together. See Figure 2.

**Step 4:** Remove the nut and washers from the valve stem of the U 5:00X5-6IT Tube (not shown) and discard. Dust the tube and the inside of the tire with talcum powder. The notch on the wheel half should be aligned with the notch for the valve stem in the opposite wheel half. The red dot on the tire is installed next to the valve stem. Add just enough air to the tube after it is in the tire to hold its shape while fitting the wheel halves.

Bolt the wheel halves together taking care that the tube is not pinched in the process.

**Step 5:** SLOWLY inflate the tire. Deflate it fully and re-inflate it SLOWLY a couple more times to work out any wrinkles in the tube. Inspect for a good seat around the wheel rim. The final inflation pressure is 22 psi.



**FIGURE 2: NOSE WHEEL & TIRE ASSEMBLY**

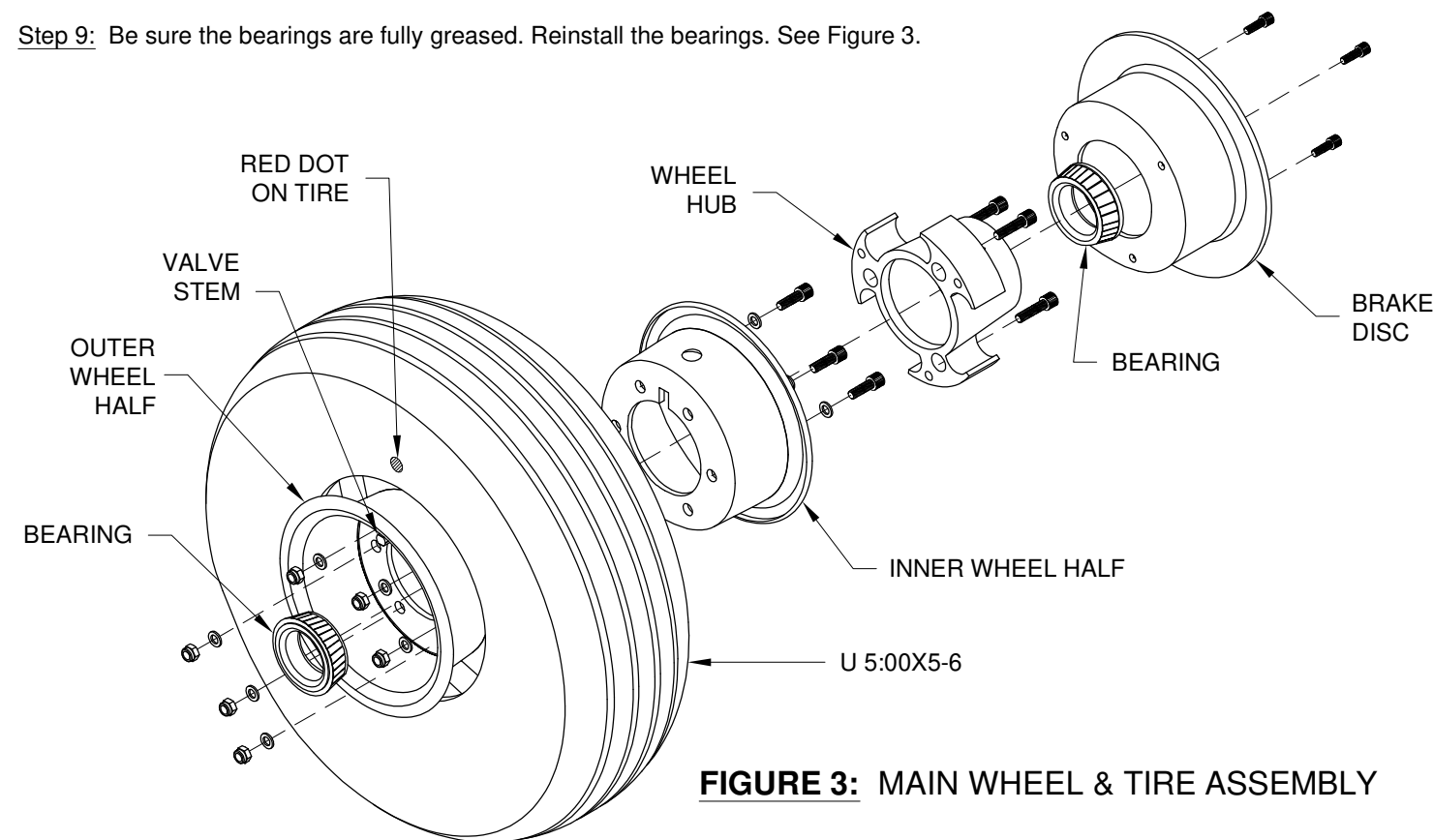
**NOTE:** Follow the instructions in Steps 6-9 for both Main Wheel and Tire Assemblies.

**Step 6:** Split the Main Wheel Assembly by removing the cap screws holding the brake disc to the wheel. Remove the bolts holding the inner and outer wheel halves together. Pay close attention to how the bearings and hubs are installed so that they can be reinstalled in the same way. Pull the bearings from the main wheel assembly then clean and dry them. See Figure 3.

**Step 7:** Remove the nut and washers from the valve stem of the U 5:00X5-6IT Tube (not shown in Figure 3) and discard. Dust the U 5:00X5-6IT Tube and the inside of the U 5:00X5-6 Tire with talcum powder then mount the tube and tire on the inner and outer wheel halves. The red dot on the tire is installed next to the valve stem of the tube (see Figure 3). Bolt the wheel halves together taking care not to pinch the tube between the wheel halves. Carefully observe the manufacturer's bolt torque specifications shown on the document in the wheel/ brake package. Attach the brake disc with the cap screws.

**Step 8:** SLOWLY inflate the tire. Deflate it fully and re-inflate it SLOWLY a couple more times to work out any wrinkles in the tube. It's a good idea to do this with the valve core removed; in the event a finger gets pinched the tire can be quickly deflated. The final inflation pressure is 28 psi.

**Step 9:** Be sure the bearings are fully greased. Reinstall the bearings. See Figure 3.

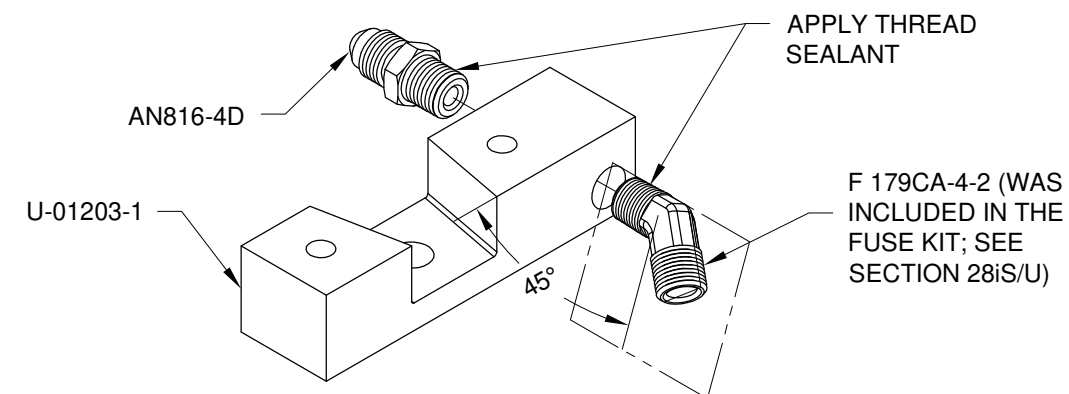


**FIGURE 3: MAIN WHEEL & TIRE ASSEMBLY**

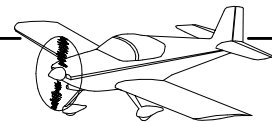
**NOTE:** Skip the following step if using the gun drilled U-01220-L-1 & -R-1 Main Landing Gear Legs.

**Step 10:** Apply a small amount of pipe thread sealant to the threads of the fluid fittings and install into the U-01203-1 Inboard Main Gear Attach Brackets as shown in Figure 4.

Set the angled fittings to a 45° angle to the top plane of the inboard main gear attach brackets as shown.



**FIGURE 4: INBOARD MAIN GEAR ATTACH BRACKET FITTINGS**



**CAUTION:** If your kit contains older-style gear legs that are not powder coated, they must be primed and painted or else they may corrode.

**Step 1:** If you would like to paint your U-01220-L-1 & -R-1 Main Landing Gear Legs (or if your U-1220-L & -R are not powder coated), roughen them with a Scotch Brite pad, clean, then prime using a two part epoxy primer (or equivalent). Paint them using a top coat compatible with the primer.

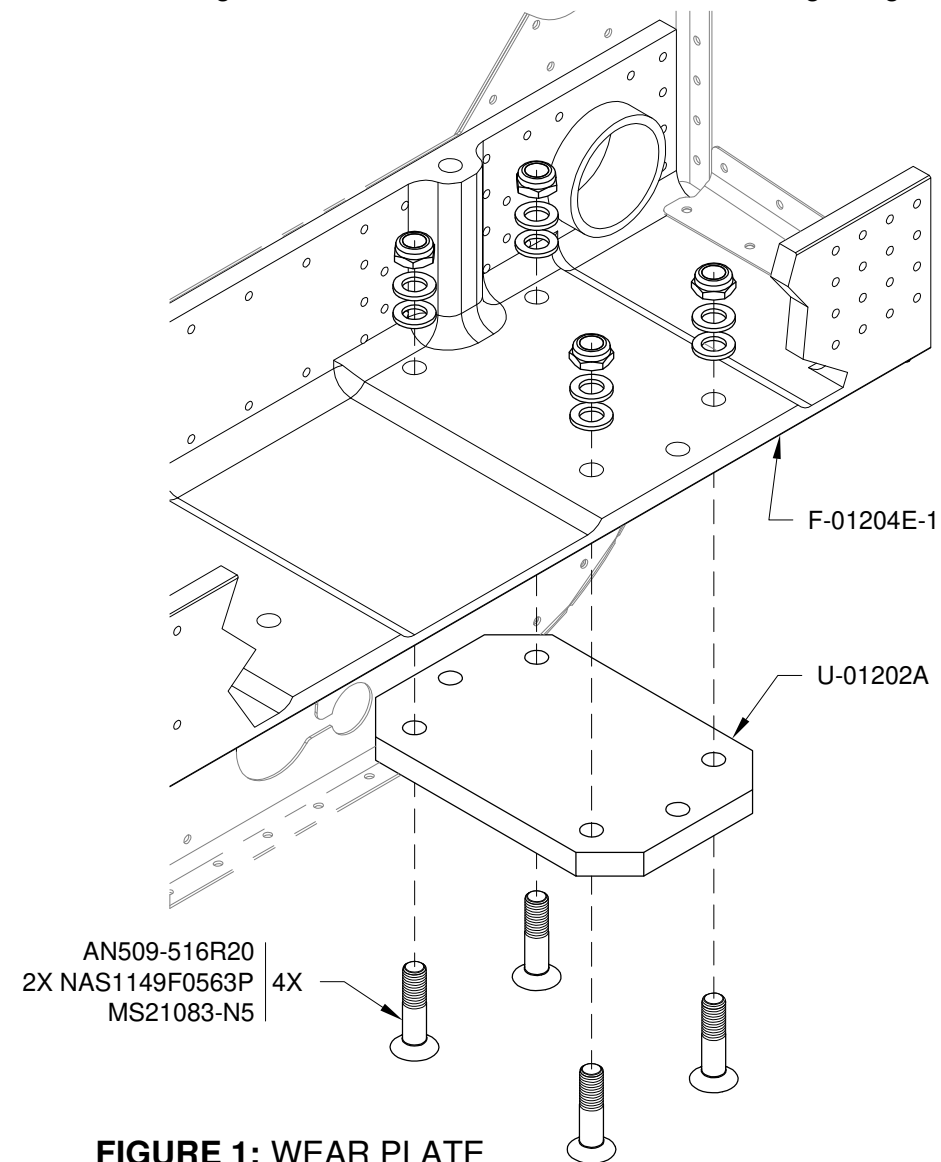
**NOTE:** The following instructions describe the right side installation. When completed with the right side, repeat the process for the left side installation.

**Step 2:** Deburr then lightly prime (keep primer thickness to a minimum) the U-01202A Outboard Wear Plates, U-01203B-1 Inboard Wear Plates and U-01203E-1 Inboard Doubler Plates.

To prevent rust, lightly coat the gear leg contact areas of the U-01202A and U-01203B-1, and the bare metal areas of the U-01202-1 and U-01203-1 with grease.

**Step 3:** Attach the U-01202A to the F-01204E-1 as shown in Figure 1. Insert the AN5 bolts shown in Figure 2 before torquing the nuts on the screws.

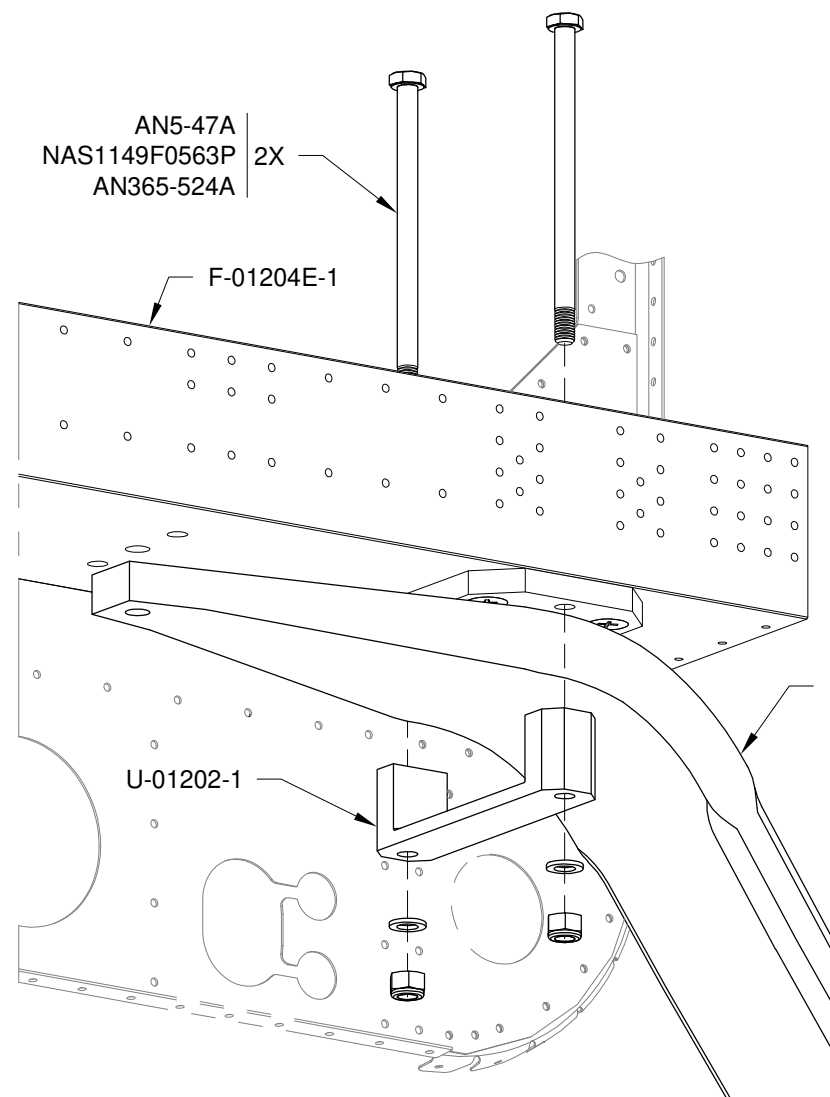
**NOTE:** On the right side of the aircraft the brake line fittings in the U-01203-1 are on the aft side of the gear leg as shown in Figure 3. On the left side of the aircraft the brake line fittings in the U-01203-1 are on the forward side of the gear leg.



**FIGURE 1: WEAR PLATE ATTACH**

**Step 4:** Maneuver the U-01220-R-1 (or U-1220-R) and U-01202-1 outboard bracket into position at the same time. See Figure 2. Install the washers and nuts but don't tighten them down yet.

**NOTE:** When torquing bolts remember to account for the prevailing torque. See Section 5.20. If using the torque wrench on the head of the bolt also account for the torque to overcome friction required to turn the shank of the bolt.



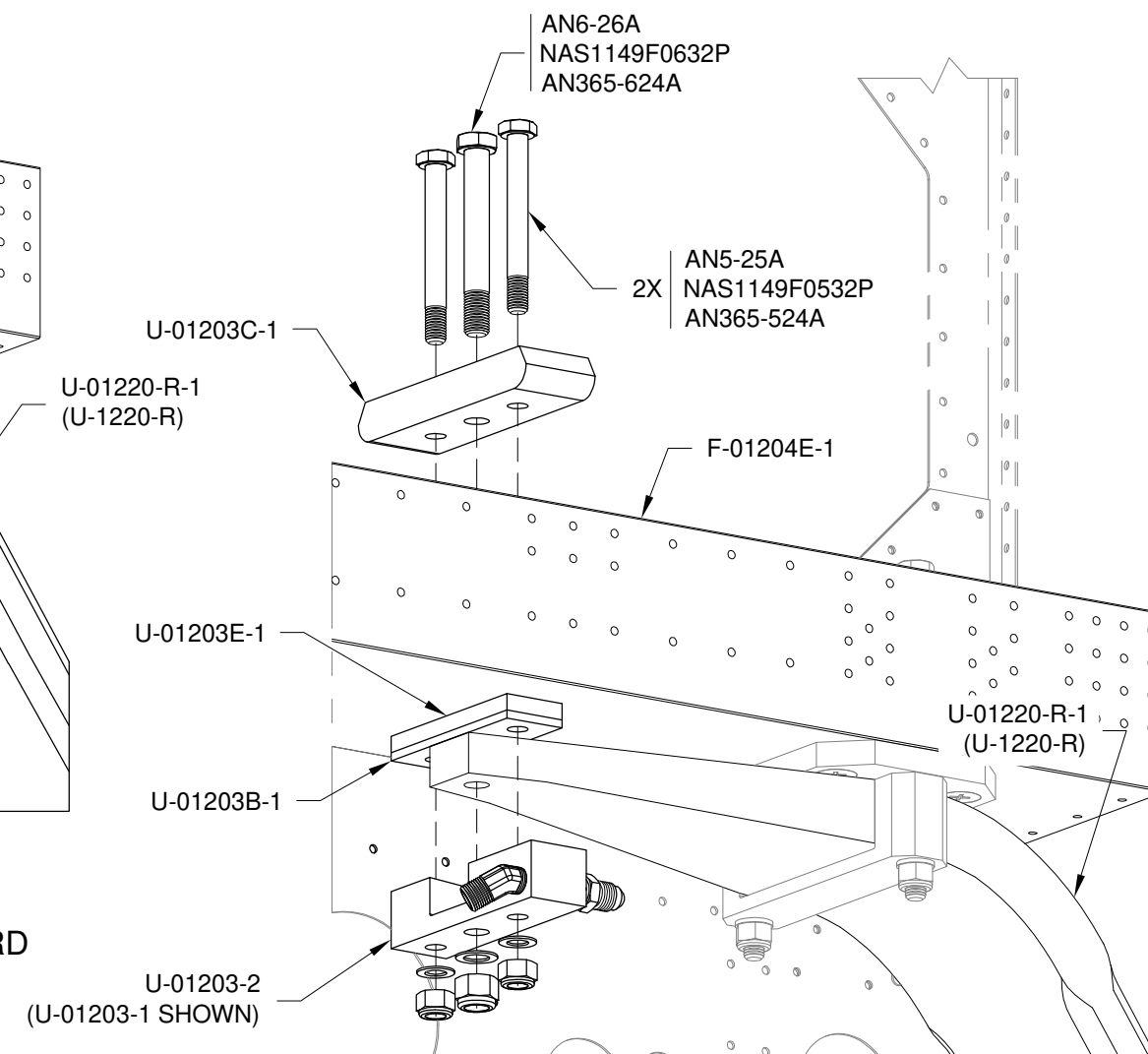
**FIGURE 2: GEAR LEG ATTACH OUTBOARD**

**Step 5:** Install the U-01203C-1, U-01203E-1, U-01203B-1, and U-01203-2 (U-01203-1 if using the older U-1220-R) using the hardware called out in Figure 3. Spacers can be used between the shop floor and the lower end of the gear leg to lever the inboard end of the leg away from the underside of the center section channel.

When the leg is properly positioned tighten and torque the three inboard bolts.

**Step 6:** Use a hammer and brass drift (or block of wood - to protect the heads of the bolts) to seat the two outboard bolts fully against the F-01204E-1. Evenly tighten the nuts, moving from one to another, while checking that the outboard main gear attach bracket is pulling up around the U-01220-R-1 (or U-1220-R) evenly (that is the gap between wear plate and gear attach bracket is the same at each bolt) until the final torque is reached.

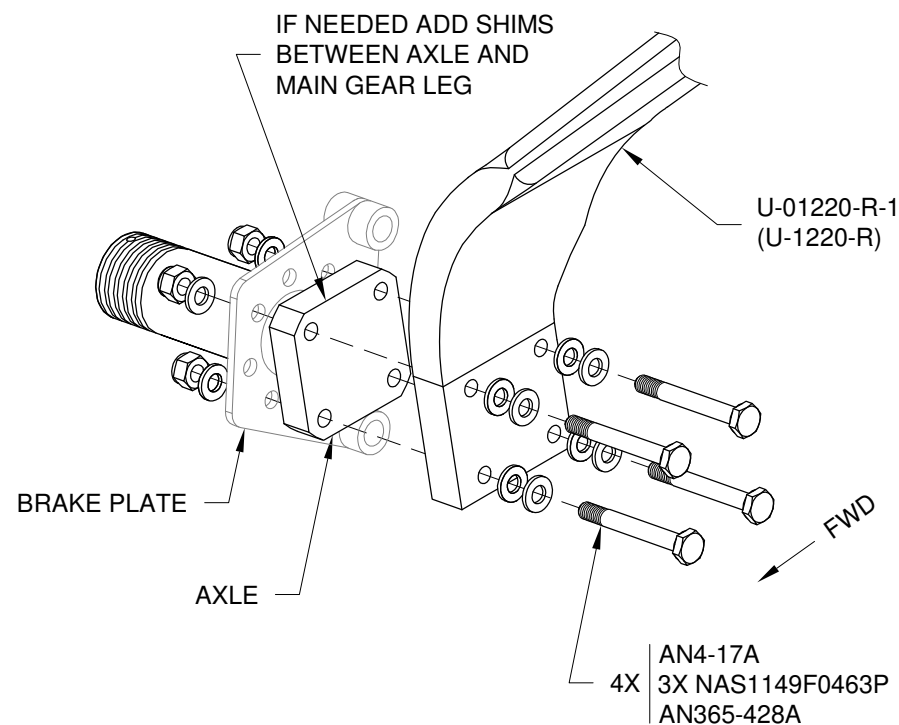
Seat the bolts again with hammer and drift then make a final check of the torque.



**FIGURE 3: GEAR LEG ATTACH INBOARD**

**NOTE: Do not attach the brake plates until the axles are aligned.**

**Step 1:** Bolt just the main gear axles to the U-01220-L-1 & -R-1 (or U-1220-L & -R) Main Landing Gear Legs with the provided hardware. See Figure 1.



**FIGURE 1:**  
ATTACHING THE MAIN GEAR AXLES  
(RIGHT AXLE/GEAR LEG SHOWN)

**NOTE:** If installing the optional wheel fairings during the build of your RV-12 refer to Section 36A and install a wheel fairing bracket while installing each axle.

**NOTE:** The C-1211 Align Blocks (or any blocks that match the dimensions in Detail A) are used as spacers and must be located on the front or back of the axles (parallel with the flats on the axle mounting flange) so that the taut thread will clear the gear leg.

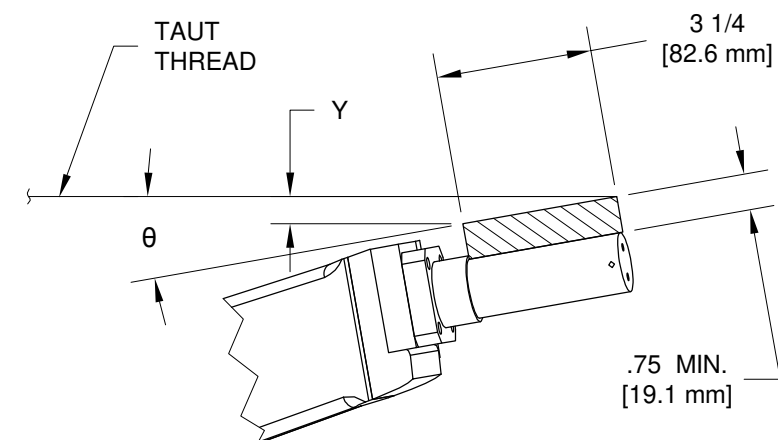
**Step 2:** Check for correct alignment between the two axles using the C-1211 Align Blocks and a taut thread as shown in Figure 2. Measure the shortest distance from the thread to the inboard corner of the block to obtain the 'Y' dimension shown in Figure 2, Detail A.

Refer to Table 1 column 'Y', locate the 'Y' value nearest to your measurement then read the angle 'θ' in the right-hand column. This is the toe-in or toe-out angle.

**Example:**

A builder measures Y = .063 [1.6 mm] and from Table 1 finds that .063 is nearest to θ = 1°. The builder orders and installs the 1° shims.

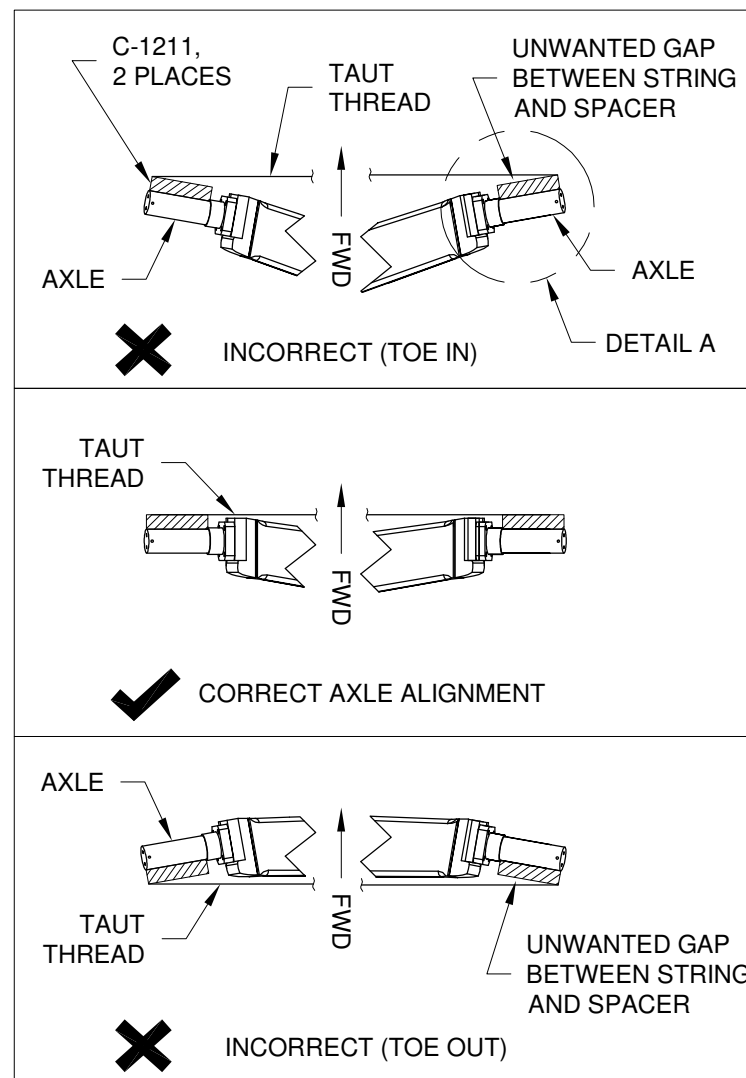
**Step 3:** If needed, add U-00013A (3/4°) or U-00013B (1/2°) shims between the axle and gear leg to align the axles as near to zero degrees as possible. Shims are available in the Van's Aircraft Accessories Catalog.



**DETAIL A**

**NOTE:** A small amount of toe-in, as long as it is less than 0.5 degrees, is preferable to any amount of toe-out.

**NOTE:** If it is suspected that axle alignment is asymmetric, a second string line parallel to the aircraft centerline may be used to align one axle. Return to the previous method and align the second axle to the first.

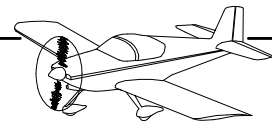


**FIGURE 2:** ALIGNING THE AXLES  
(BOTTOM VIEW)

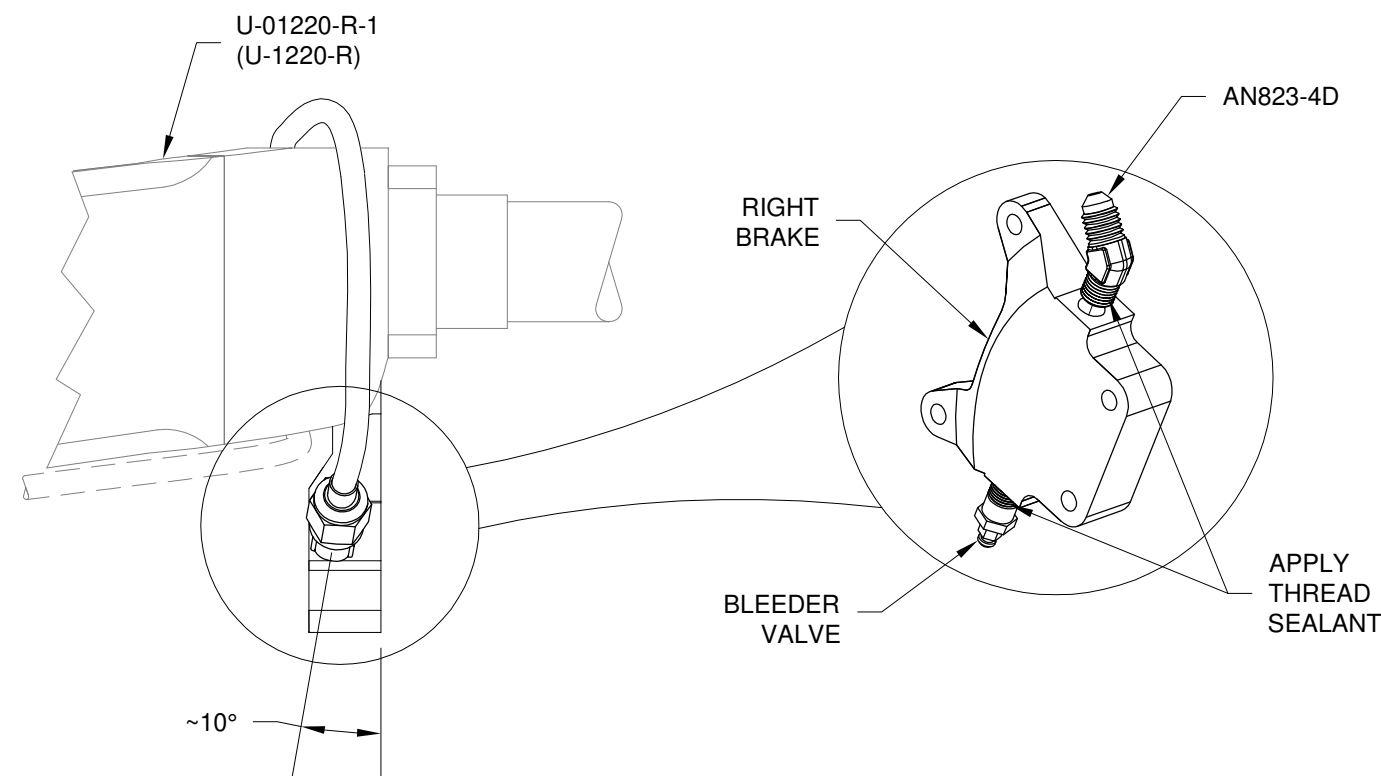
TOE-IN / TOE-OUT ANGLE (for block length L = 3-1/4 in. [82.6 mm] )	
Y	Angle θ
0.014 in. [0.4 mm]	0.25°
0.028 in. [0.7 mm]	0.49°
0.057 in. [1.4 mm]	1.00°

**TABLE 1**

*Reference only: For block lengths measuring other than 3-1/4 in. (and for a good time) the angle θ may be calculated using the formula:  
θ = SIN<sup>-1</sup>(Y/L)  
(where L is the block length)*



**Step 1:** Apply pipe thread sealant and attach the fluid fittings to the brake as shown in Figure 1. Angle the elbow fitting about 10° outboard to direct the brake line away from the the gear leg. Note that the brakes should mirror each other when installed.

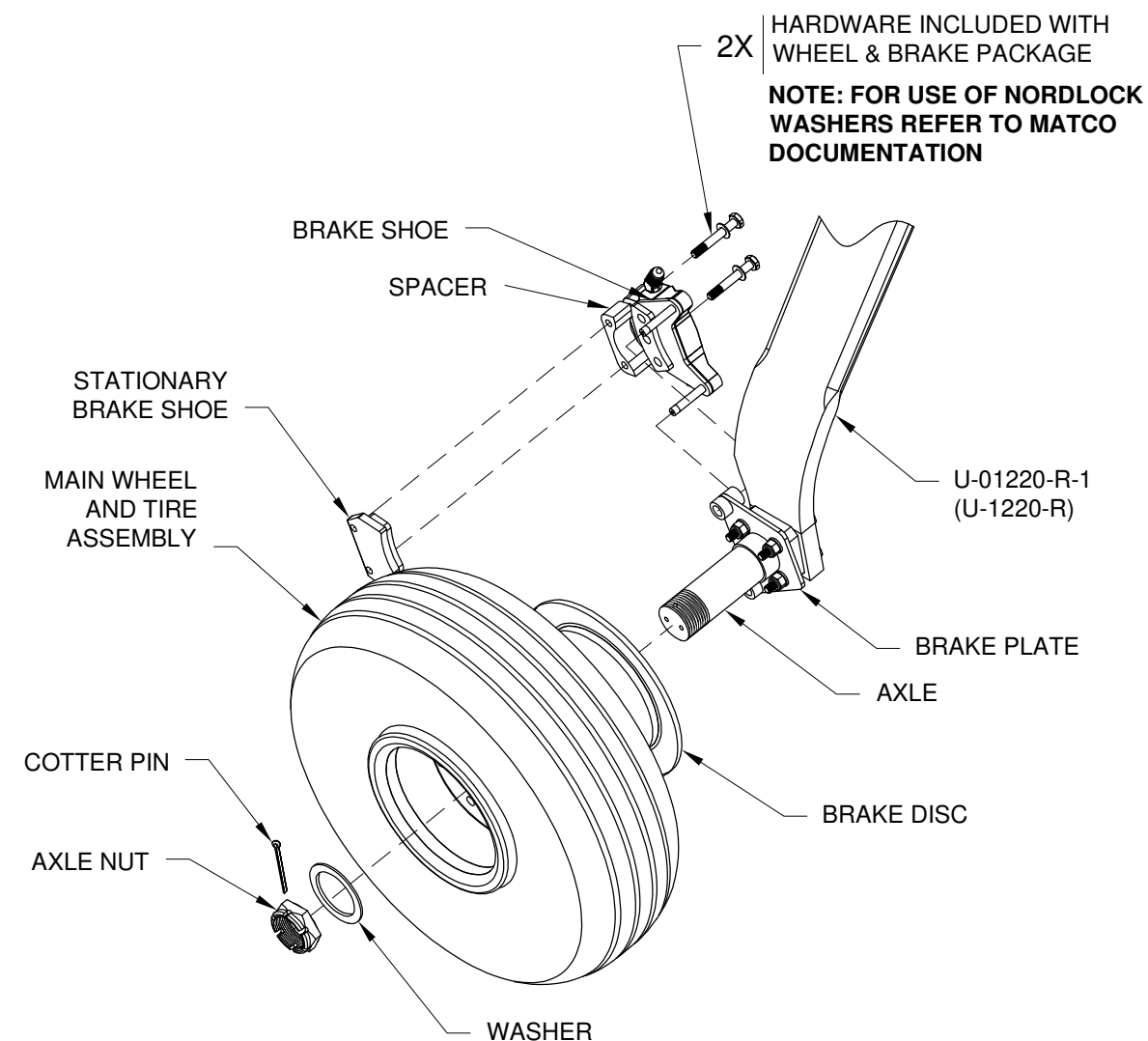


**FIGURE 1:**  
**ADDING FITTINGS TO BRAKE ASSEMBLY**  
 (TOP VIEW, RIGHT SIDE SHOWN; PARTS OMITTED FOR CLARITY)

**Step 2:** Slide the Main Gear Wheel Assembly and washer onto the axle and secure with the axle nut as shown in Figure 2. The axle nut should be tightened to the point that there is no play in the assembly and the rubber seal on the bearing doesn't spin with the wheel. See the instructions included with the wheel and brake package for further details on axle nut torque. Install the cotter pin as shown in Figure 2.

**Step 3:** Install left and right side Brake Assemblies as shown in Figure 2. Slide the studs of the Cylinder Assembly into the brake plate, place the stationary brake shoe behind the brake disc, then bolt the stationary brake shoe and Cylinder Assembly together. The bleeder valve should be on the bottom of the Brake Assembly when installed as shown on Page 35iS/U-06, Figure 2, Section A-A.

**Step 4:** Lower the fuselage onto the main gear.



**FIGURE 2:** ATTACHING THE WHEELS AND BRAKES



**NOTE:** Skip this page if using the gun drilled U-01220-L-1 & -R-1 Main Landing Gear Legs.

**NOTE:** See Section 5.14 for detailed instructions on tube flaring and installation.

**Step 1:** Make the F-1289D-L Caliper Brake Line by unrolling the AT0-032X1/4 aluminum tubing against a work table and cutting a piece to 43 3/4 in. [111.1 cm].

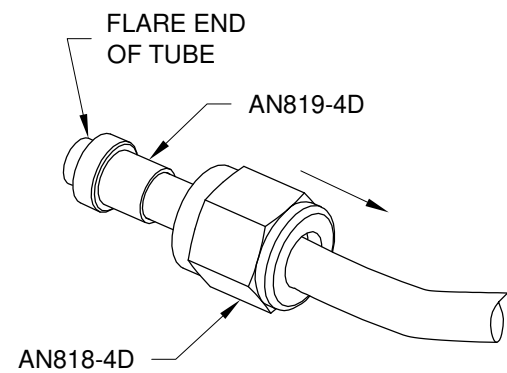
Make the F-1289D-R Caliper Brake Line by unrolling the AT0-032X1/4 aluminum tubing and cutting a piece to 41 1/2 in. [105.4 cm].

Slip a nut and collar on each tube, polish and flare the end on each caliper brake line as shown in Figure 1. Add another nut and collar on each tube and polish and flare the unfinished end of the tube.

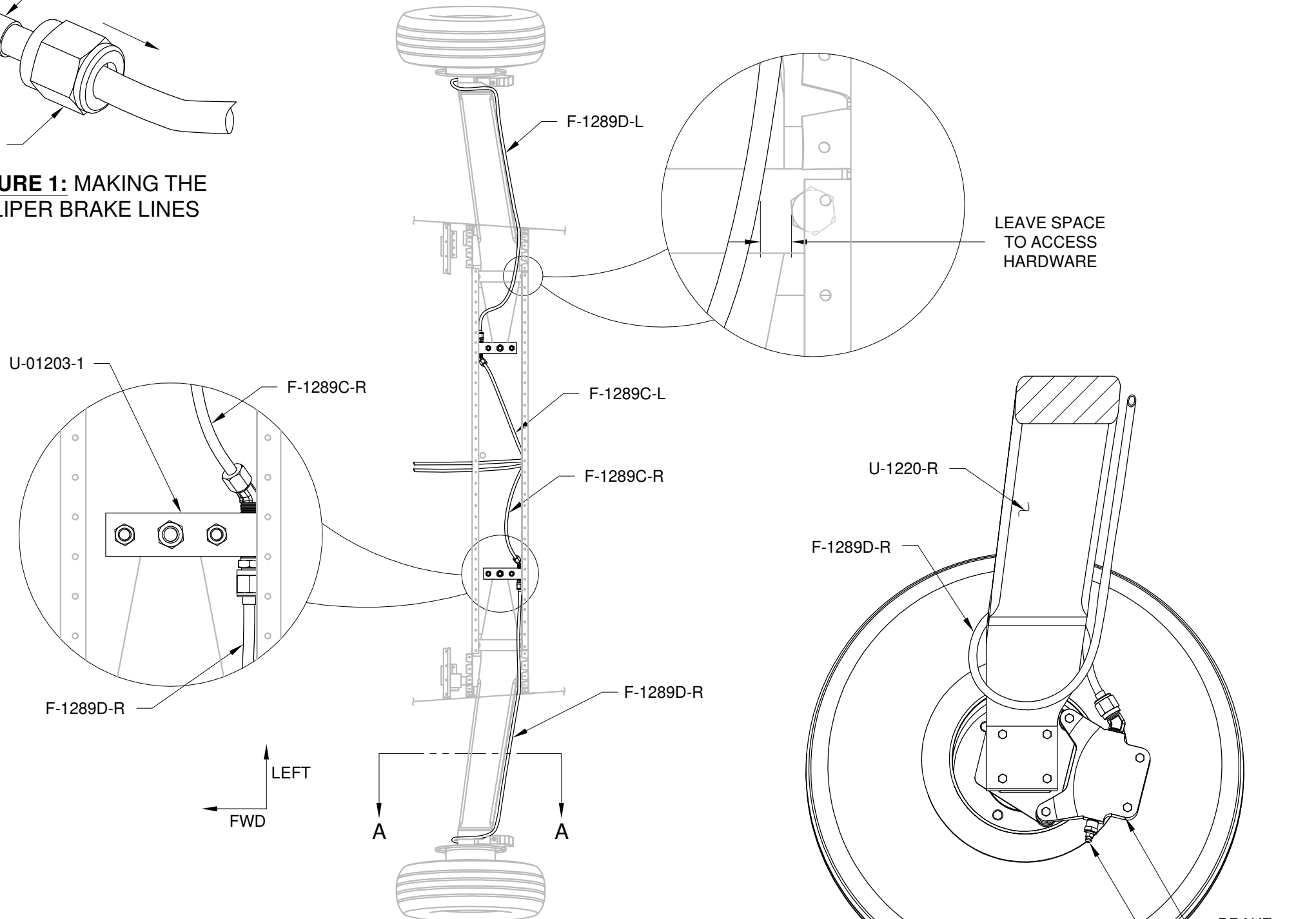
**NOTE:** See Section 5.22 for detailed compression fitting assembly instructions.

**Step 2:** Attach the F-1289C-L and F-1289C-R Main Brake Lines to the fittings in the U-01203-1 Inboard Main Gear Attach Brackets as shown in Figure 2. Attach the F-1289D-L and F-1289D-R Caliper Brake Lines to the AN fitting installed on the inboard main gear attach brackets using the hardware installed in Step 1.

**Step 3:** Route the F-1289D-L and F-1289D-R Caliper Brake Lines as shown in Figure 2. Take care that the lines are routed aft of the gear leg, and that the caliper brake lines are clear of the gear leg installation hardware. Attach the caliper brake lines to the fluid fittings on the brake assemblies using the hardware installed in Step 1.

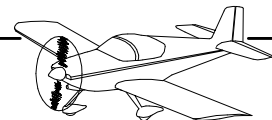


**FIGURE 1: MAKING THE CALIPER BRAKE LINES**



**FIGURE 2: ATTACHING THE CALIPER BRAKE LINES (BOTTOM VIEW)**

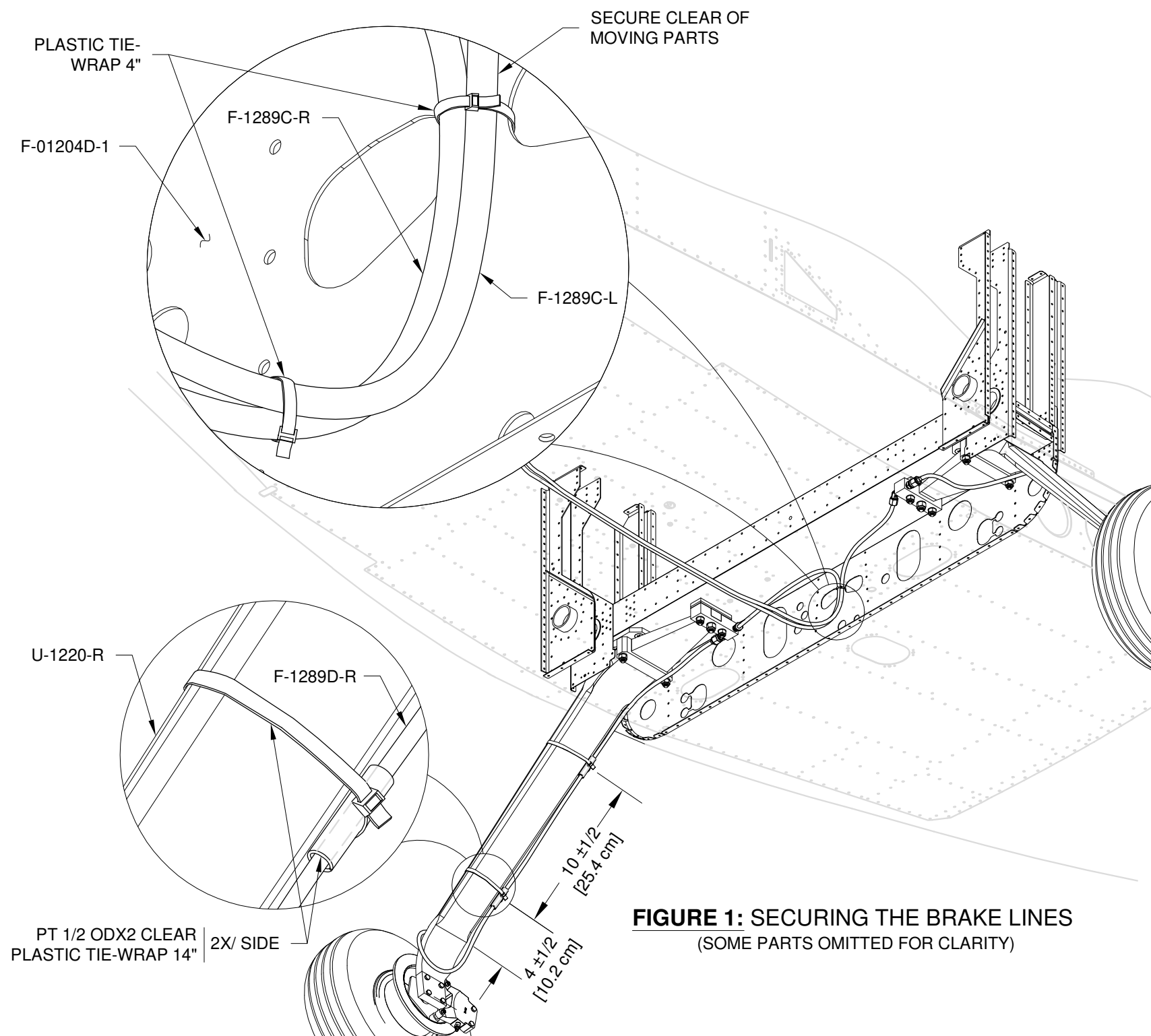
**SECTION A-A (VIEW ROTATED 180°)**



**NOTE:** Skip this page if using the gun drilled U-01220-L-1 & -R-1 Main Landing Gear Legs.

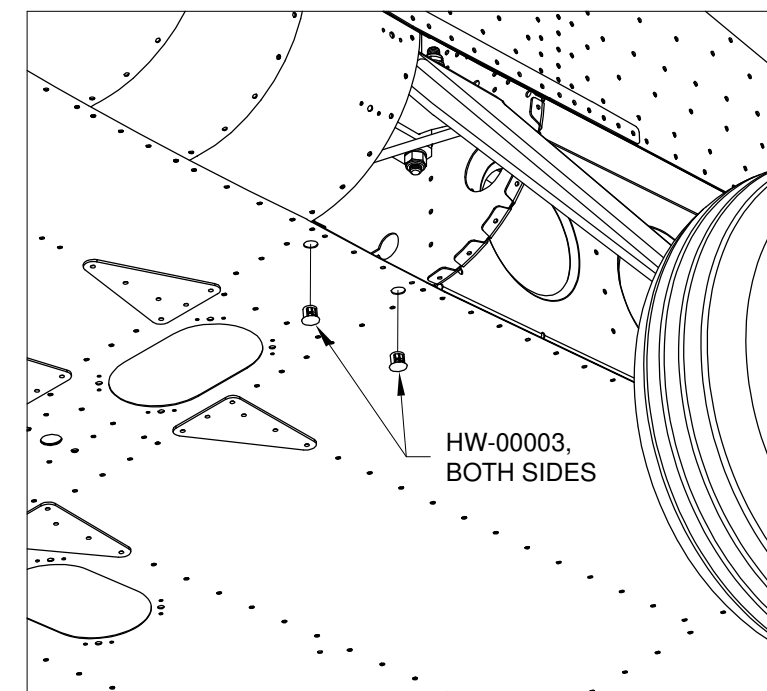
**Step 1:** Secure the F-1289C-L and F-1289C-R Main Brake Lines to the F-01204D-1 and to each other with the provided tie-wraps as shown in Figure 1.

**Step 2:** Make a slit in one side of the provided PT 1/2ODX2 CLEAR tubing. Slip the pieces of tubing around the F-1289D-L and F-1289D-R and secure the tubing pieces and caliper brake lines with the provided tie-wraps as shown in Figure 1.

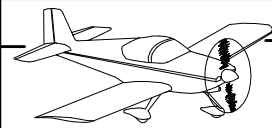


**FIGURE 1: SECURING THE BRAKE LINES**  
(SOME PARTS OMITTED FOR CLARITY)

**Step 3:** Install HW-00003 Dome Plugs as shown in Figure 2.



**FIGURE 2: DOME PLUG INSTALLATION**



**NOTE:** Skip this page if using the older-style U-1220-L & -R Main Landing Gear Legs.

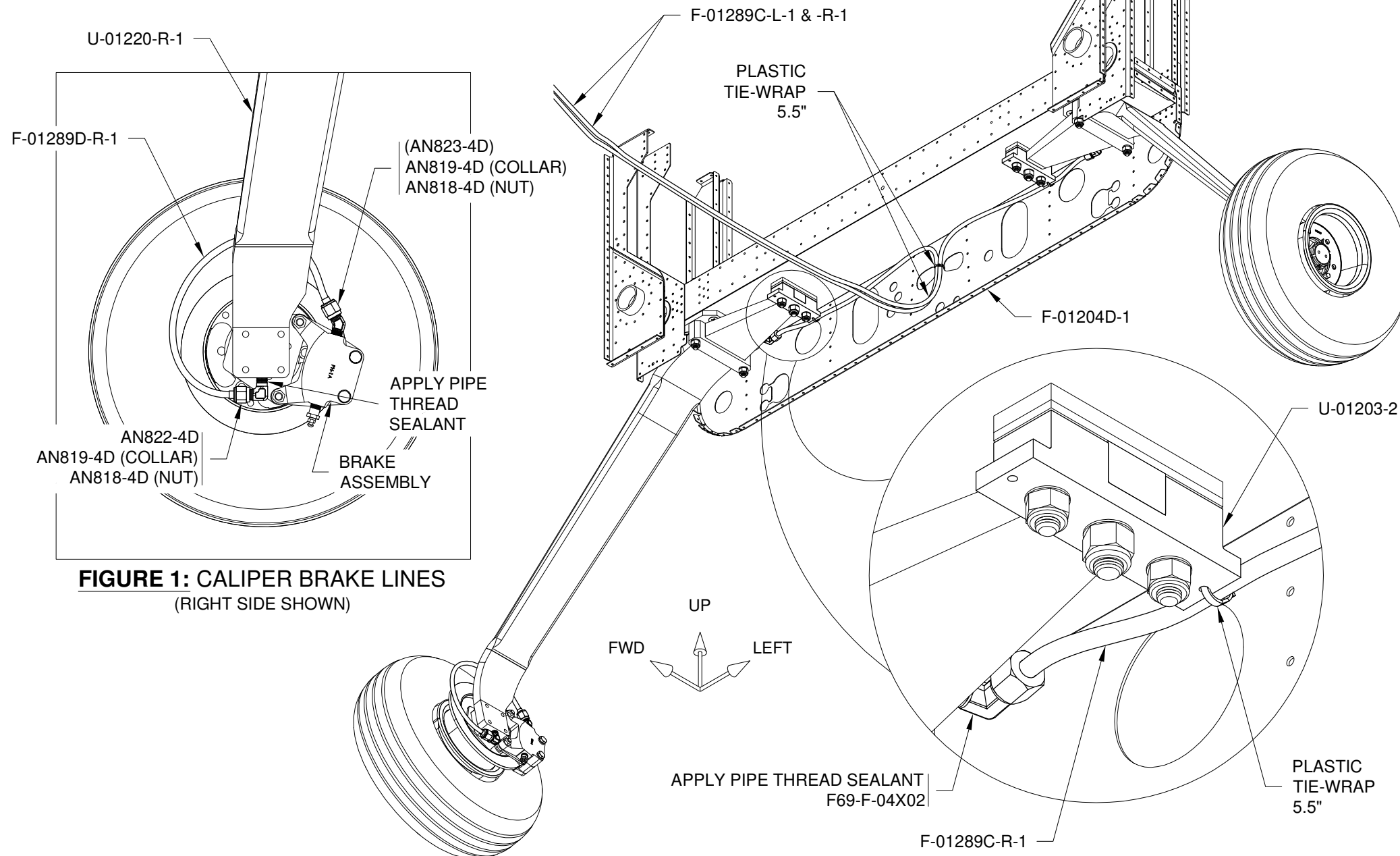
**Step 1:** Blow compressed air through each gear leg brake fluid cavity prior to installing fittings to ensure that it is clear of any debris.

Apply a small amount of pipe thread sealant to the 90° elbow fitting shown in Figure 1 and install it into the bottom port on the U-01220-R-1 Main Landing Gear Leg. Repeat for the left side.

**NOTE:** See Section 5.14 for instructions on tube flaring and installation.

**Step 2:** Cut two 13 3/4 in. [34.9 cm] long pieces of AT0-032X1/4 aluminum tubing to make the F-01289D-L-1 & -R-1 Caliper Brake Lines.

**Step 3:** Slip a nut and collar over each end of each F-01289D-L-1 & -R-1. Polish and flare the ends. See Figure 1.



**FIGURE 1: CALIPER BRAKE LINES**  
(RIGHT SIDE SHOWN)

**FIGURE 2: GUN DRILLED GEAR LEG BRAKE LINES**

**Step 4:** Bend, then attach the F-01289D-L-1 & -R-1 to the elbow fittings on the U-01220-L-1 & -R-1 and to the fluid fittings on the brake assemblies as shown in Figure 1. Ensure that the F-01289D-L-1 & -R-1 are clear of the U-01220-L-1 & -R-1.

**Step 5:** Apply a small amount of pipe thread sealant to the compression fitting (previously attached to the main brake line in Section 28iS/U) shown in the detail view of Figure 1 and install it into the aft port on the U-01220-R-1 Main Landing Gear Leg. Repeat for the left side.

**NOTE:** See Section 5.22 for detailed compression fitting assembly instructions.

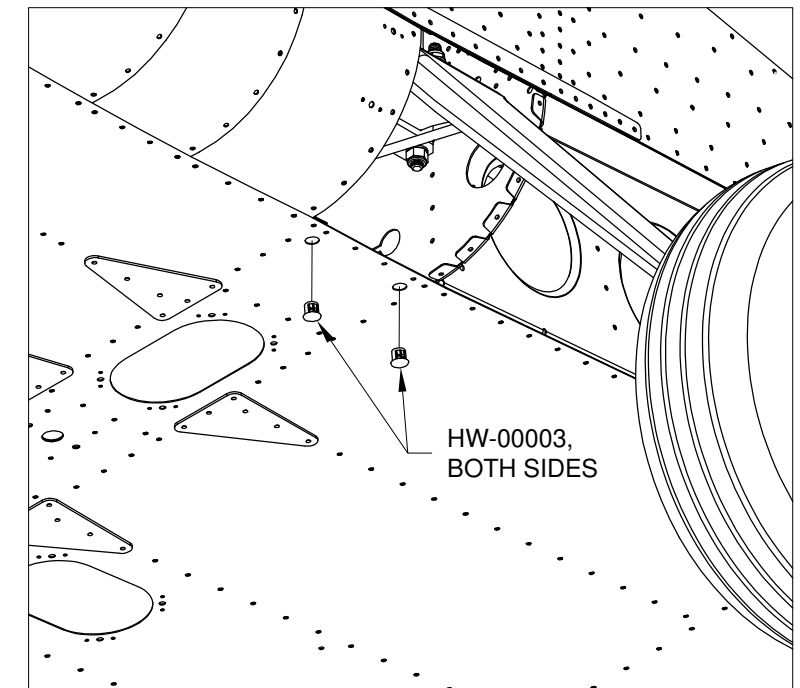
**Step 6:** Route the F-01289C-L-1 & -R-1 Main Brake Lines to the compression fittings in the U-01220-L-1 & -R-1 as shown in Figure 2.

Trim the F-01289C-L-1 & -R-1 as required to remove excess tubing (verify that rudder pedal movement is not restricted), then attach to the compression fittings.

**Step 7:** Tie-wrap the F-01289C-L-1 & -R-1 to the left and right U-01203-2. See the detail view of Figure 2.

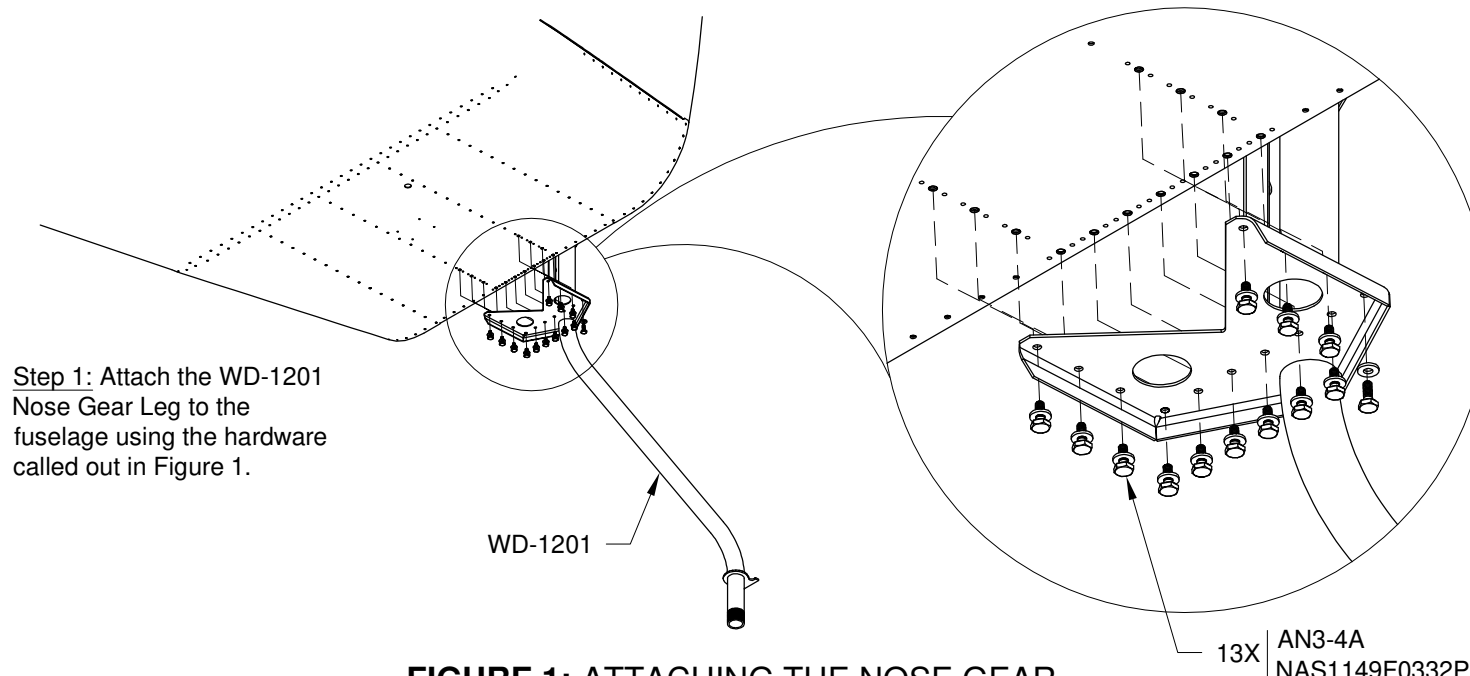
**Step 8:** Tie-wrap the F-01289C-L-1 & -R-1 to the F-01204D-1 and to each other as shown in Figure 2.

**Step 9:** Install the HW-00003 Dome Plugs as shown in Figure 3.



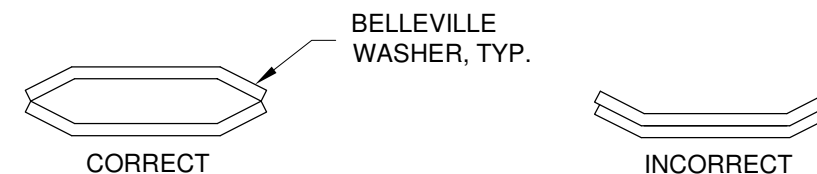
**FIGURE 3: DOME PLUG INSTALLATION**





Step 1: Attach the WD-1201 Nose Gear Leg to the fuselage using the hardware called out in Figure 1.

**FIGURE 1: ATTACHING THE NOSE GEAR**



**FIGURE 3: BELLEVILLE WASHER ORIENTATION (NOT TO SCALE)**

**NOTE: If installing the optional wheel fairings refer to Section 36A and install the wheel fairing brackets on the nose fork before completing the steps on this page.**

Step 2: Apply Loctite #243 to the threads of the 5/16-24X3/4 screws. Install the screws into the WD-01230-1 Nose Fork as shown in Figure 2.

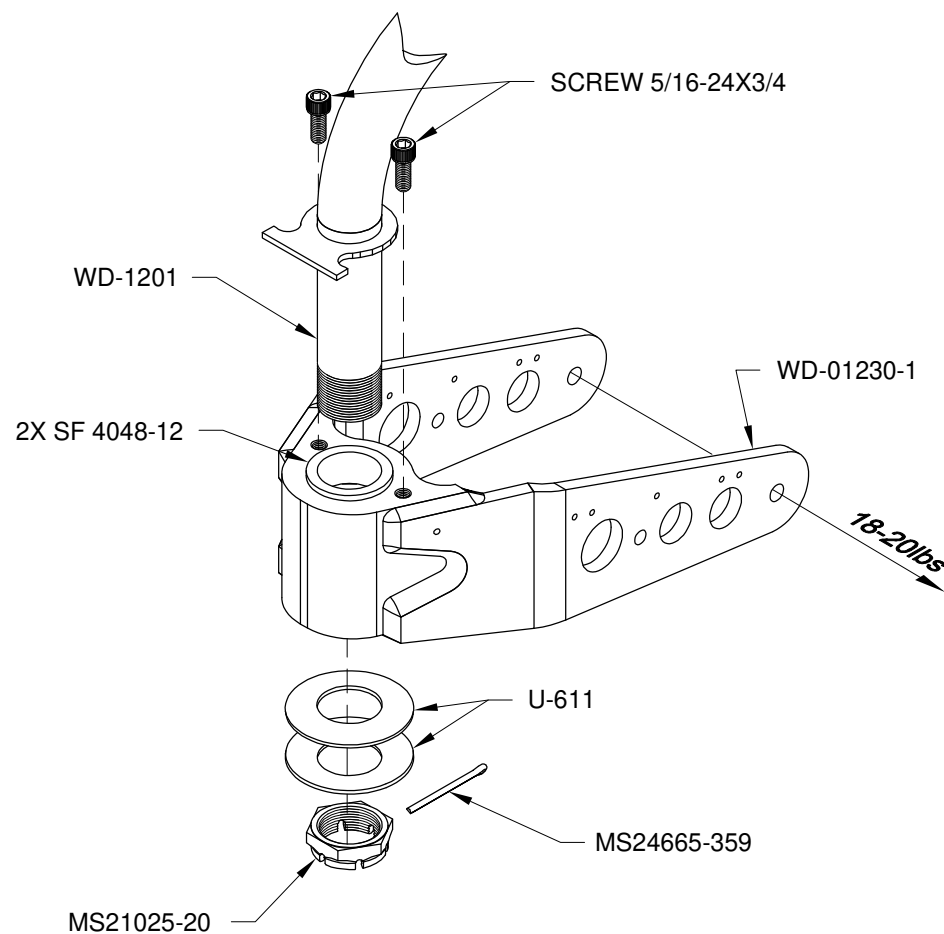
Step 3: Grease the SF 4048-12 Bronze Bushings with Aeroshell #5, (Blue) Marine/Boat Trailer Grease or equivalent.

Slide the Nose Fork Assembly and the two U-611 Washers onto the WD-1201 Nose Gear Leg. The U-611 washers are "cupped" and to function properly the outside perimeter of both washers must be in contact with each other when installed. See Figure 3.

Thread on the MS21025-20 Nut.

Step 4: Thread safety wire through the bolt holes used to secure the Nose Wheel and Tire Assembly to the Nose Fork Assembly, then attach a spring scale to the end of the safety wire. Tighten the MS21025-20 Nut until a force of 18-20 lbs is measured as the Nose Fork Assembly pivots around the spindle.

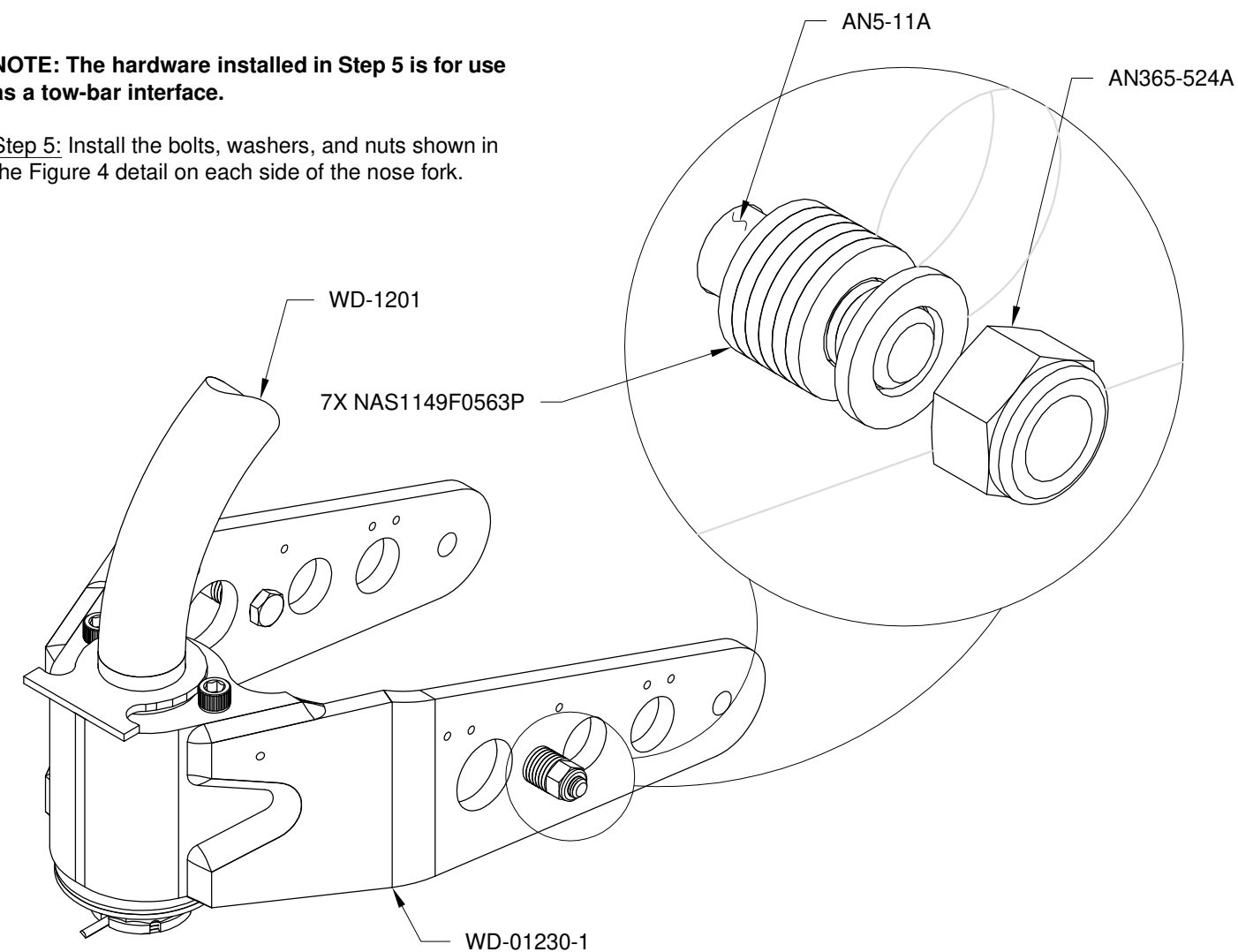
Use the nut as a drill guide and match-drill #30 both sides of the nose gear leg for the cotter pin. To prevent accidental rotation, insert the cotter pin after the first hole is drilled. Deburr as required then secure the nut with the cotter pin called out in Figure 2.



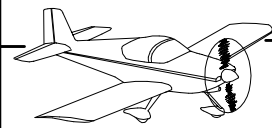
**FIGURE 2: INSTALLING THE NOSE FORK ASSEMBLY**

**NOTE: The hardware installed in Step 5 is for use as a tow-bar interface.**

Step 5: Install the bolts, washers, and nuts shown in the Figure 4 detail on each side of the nose fork.



**FIGURE 4: ADDING HARDWARE TO NOSE FORK**

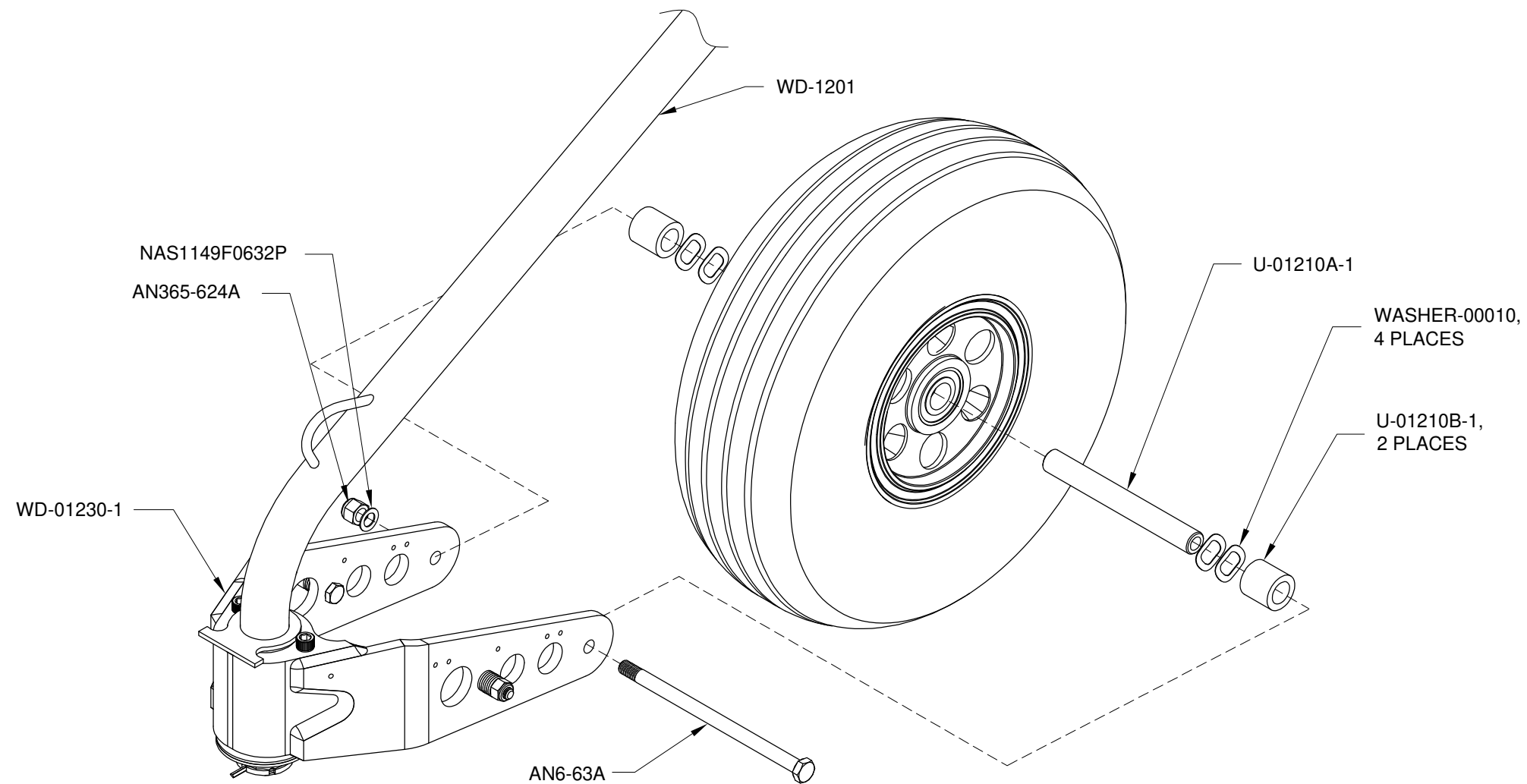


**Step 1:** Assemble the U-01210A-1 Axle, WASHER-00010 Wave Washers, and the U-01210B-1 Spacers as shown in Figure 1.

Bolt the Nose Wheel and Tire Assembly to the Nose Fork Assembly using the hardware called out in Figure 1.

**NOTE:** The fuselage may now be lowered onto the nose wheel.

**Step 2:** Fill the brake system with the brake fluid recommended in the wheel and brake package instructions. Follow the instructions in the wheel and brake package for bleeding the brake system (note that the loop around the base of the main gear legs is standard for RV aircraft and has not hindered the removal of air from the brake system).



**FIGURE 1:** INSTALLING THE NOSE WHEEL & TIRE ASSEMBLY