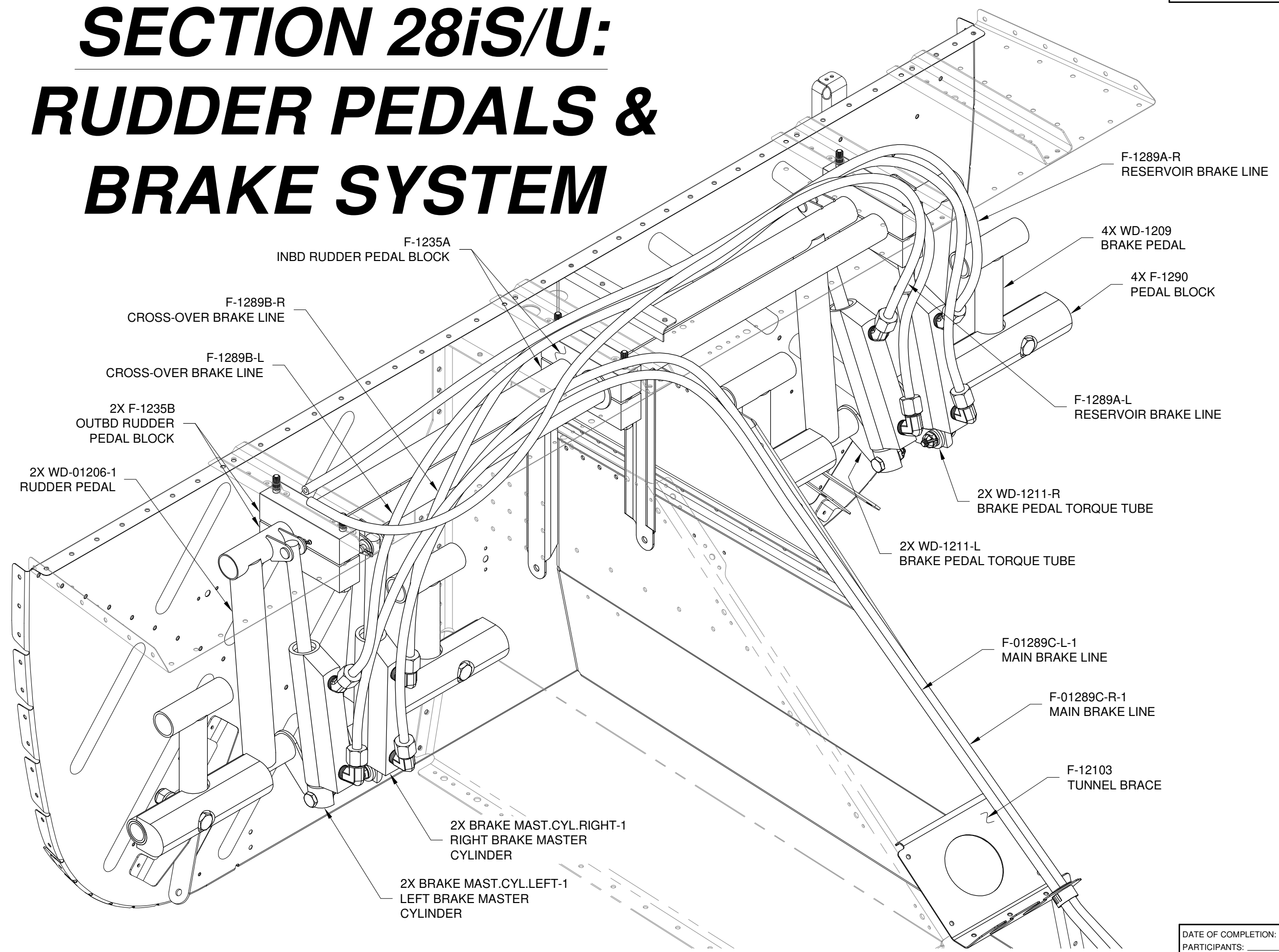


# SECTION 28iS/U: RUDDER PEDALS & BRAKE SYSTEM



F-1235A  
INBD RUDDER PEDAL BLOCK

F-1289A-R  
RESERVOIR BRAKE LINE

F-1289B-R  
CROSS-OVER BRAKE LINE

4X WD-1209  
BRAKE PEDAL

F-1289B-L  
CROSS-OVER BRAKE LINE

4X F-1290  
PEDAL BLOCK

2X F-1235B  
OUTBD RUDDER  
PEDAL BLOCK

F-1289A-L  
RESERVOIR BRAKE LINE

2X WD-01206-1  
RUDDER PEDAL

2X WD-1211-R  
BRAKE PEDAL TORQUE TUBE

2X WD-1211-L  
BRAKE PEDAL TORQUE TUBE

F-01289C-L-1  
MAIN BRAKE LINE

F-01289C-R-1  
MAIN BRAKE LINE

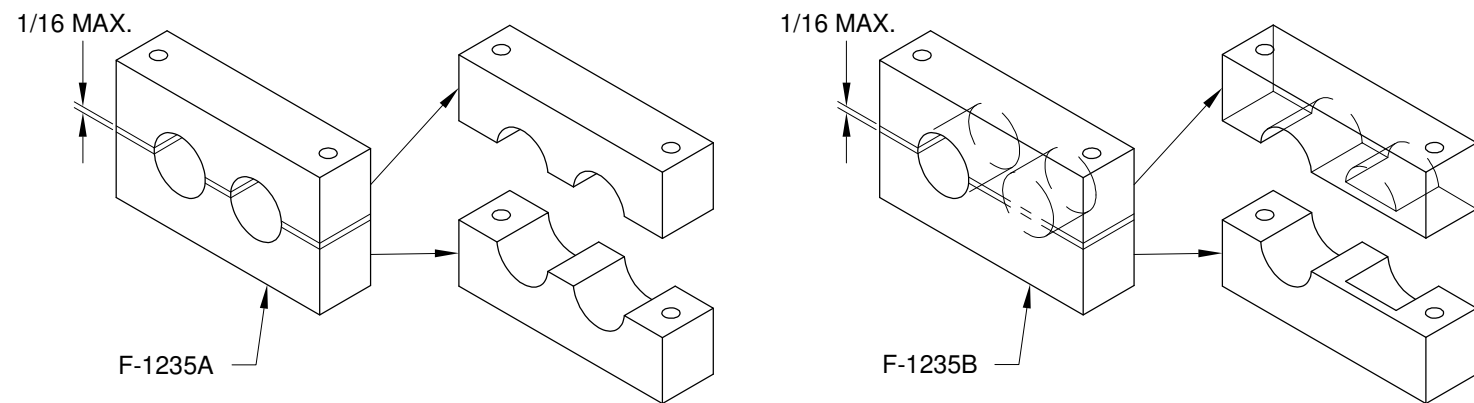
F-12103  
TUNNEL BRACE

2X BRAKE MAST.CYL.RIGHT-1  
RIGHT BRAKE MASTER  
CYLINDER

2X BRAKE MAST.CYL.LEFT-1  
LEFT BRAKE MASTER  
CYLINDER

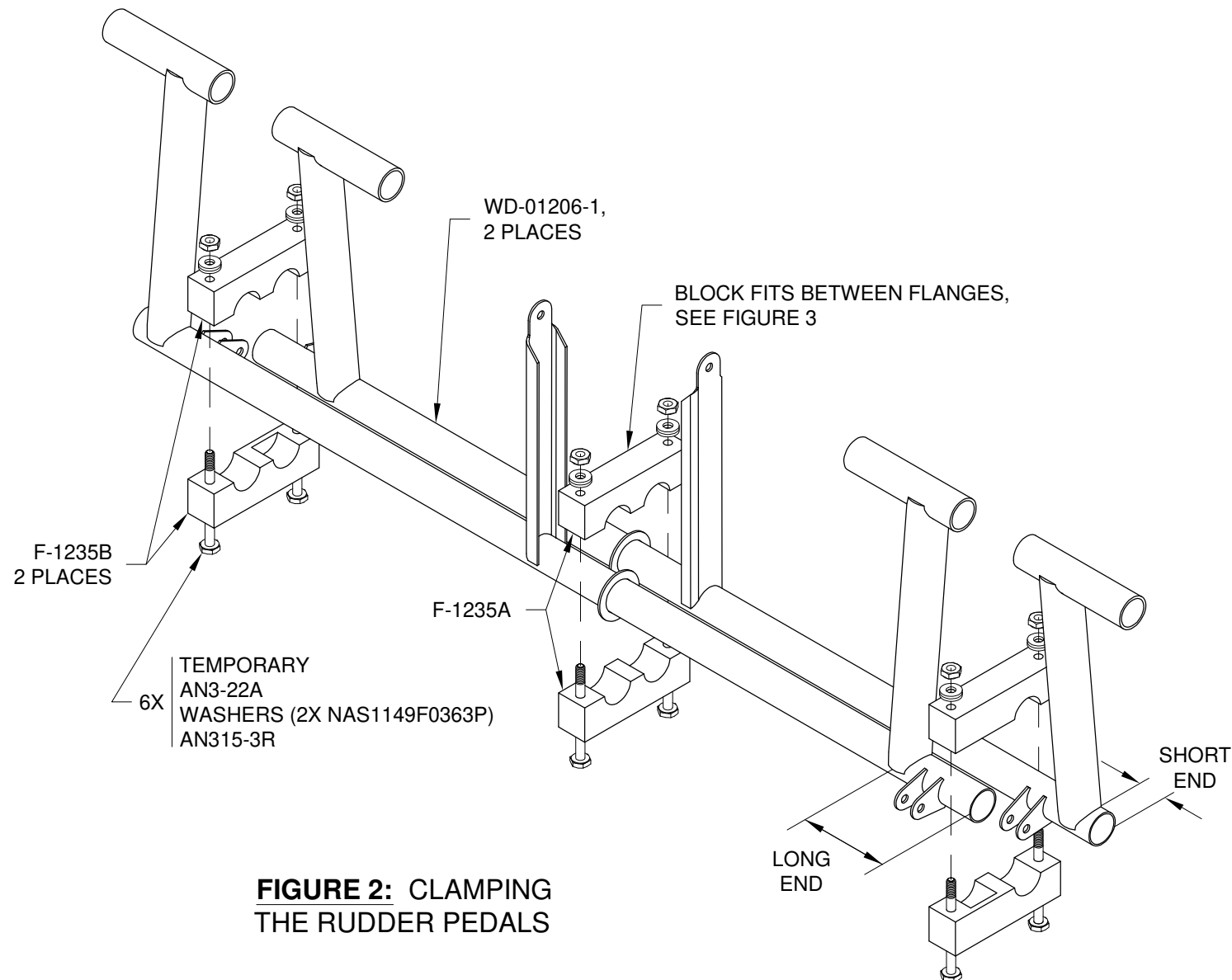


Step 1: Cut the F-1235A Inbd Rudder Pedal Block and the two F-1235B Outbd Rudder Pedal Blocks as shown in Figure 1. Mark the split parts so that they remain together and so that they can be assembled in their original, pre-split orientation.



**FIGURE 1: CUT THE INBD AND OUTBD RUDDER PEDAL BLOCKS**

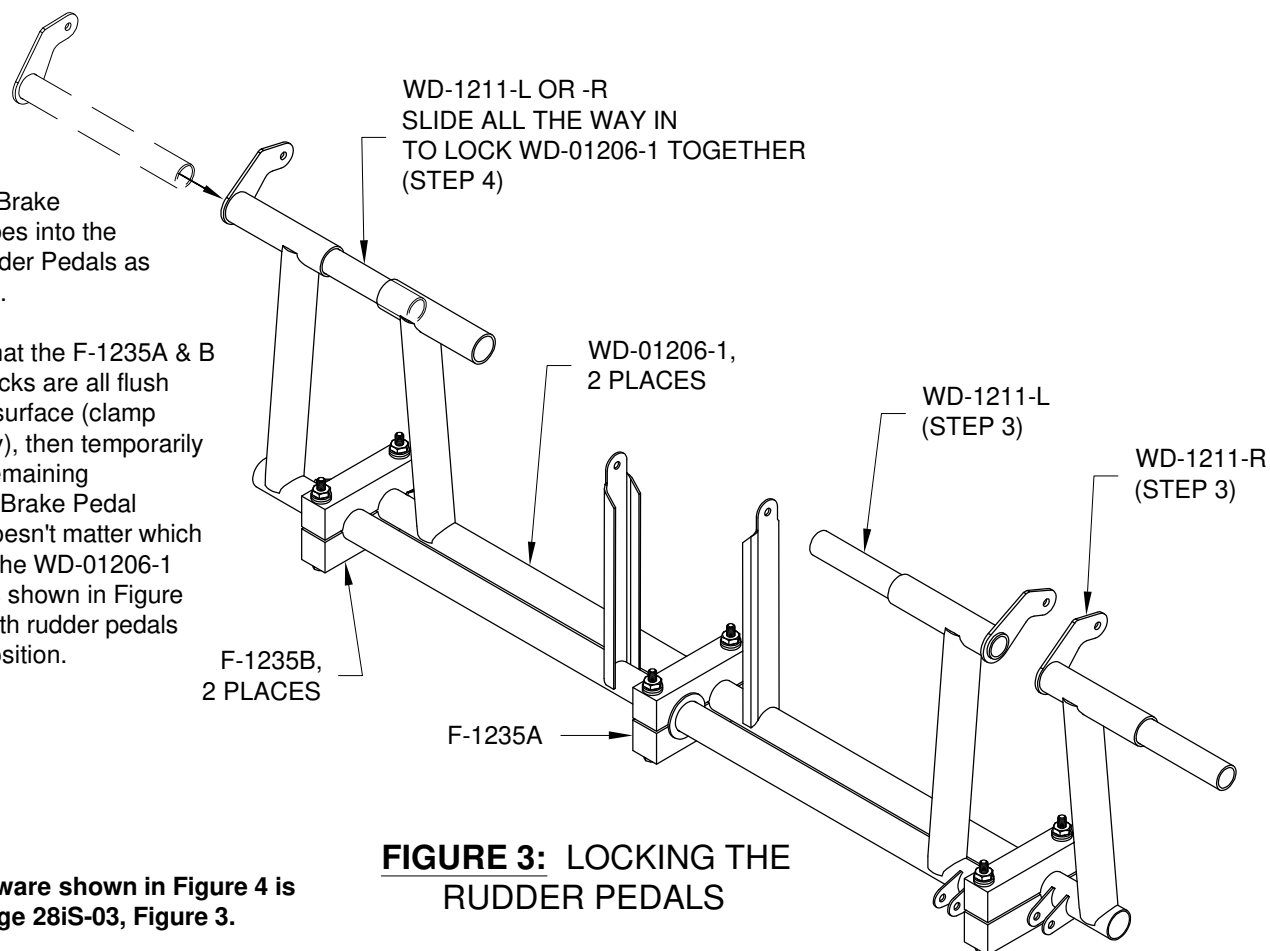
Step 2: Temporarily clamp the WD-01206-1 Rudder Pedals using the F-1235A & B Rudder Pedal Blocks as shown in Figure 2. Be sure the rudder pedals are oriented as shown in the figure (long end and short end together), and place the heads of the bolts on the bottom so that the clamped assembly will lay flat on the work surface.



**FIGURE 2: CLAMPING THE RUDDER PEDALS**

Step 3: Slide the WD-1211-L & -R Brake Pedal Torque Tubes into the WD-01206-1 Rudder Pedals as shown in Figure 3.

Step 4: Be sure that the F-1235A & B Rudder Pedal Blocks are all flush against the work surface (clamp down if necessary), then temporarily slide one of the remaining WD-1211-L or -R Brake Pedal Torque Tubes (doesn't matter which one) into both of the WD-01206-1 Rudder Pedals as shown in Figure 3. This will lock both rudder pedals into the neutral position.

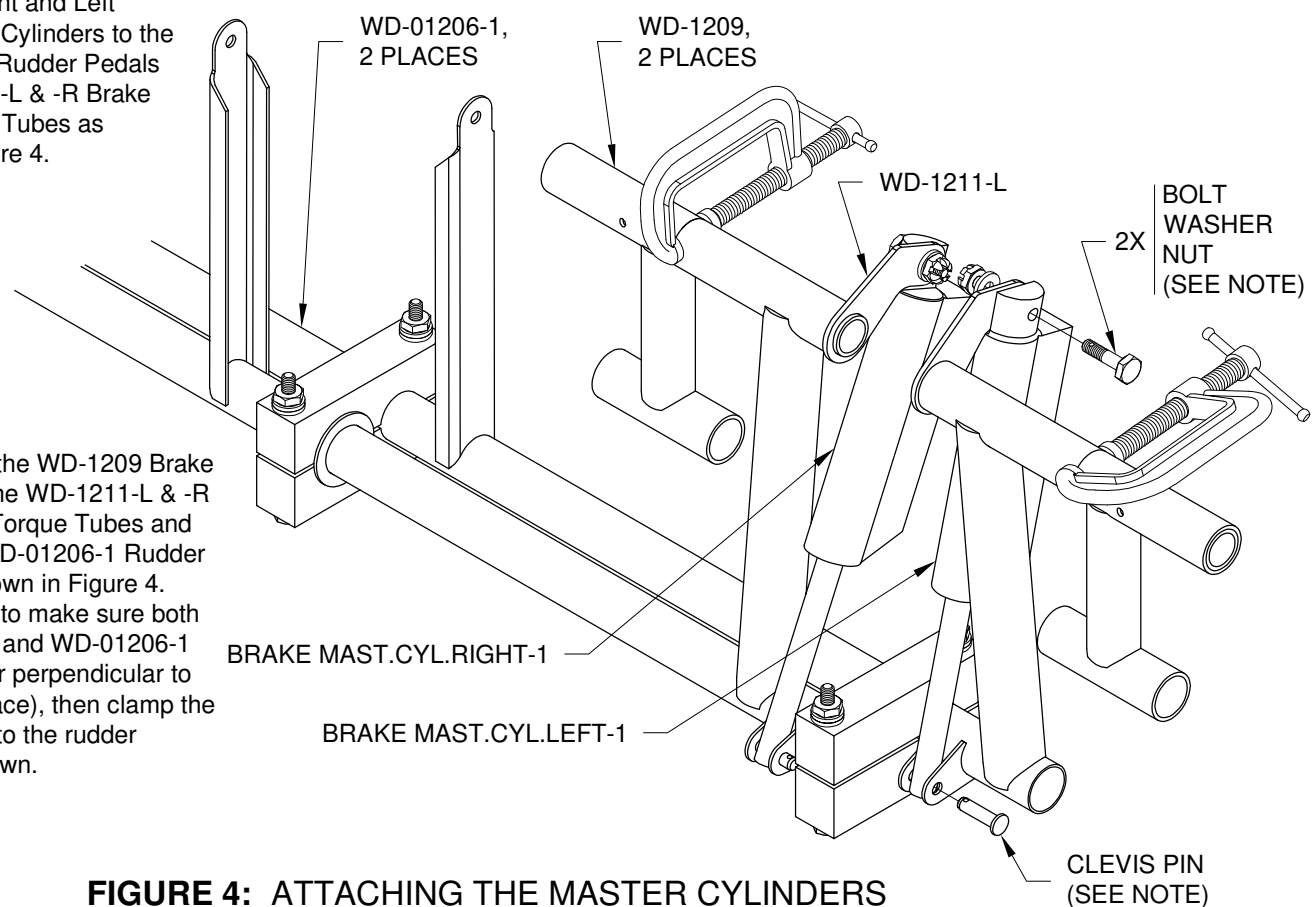


**FIGURE 3: LOCKING THE RUDDER PEDALS**

**NOTE:** The hardware shown in Figure 4 is called out on Page 28iS-03, Figure 3.

Step 5: Temporarily attach the BRAKE MAST.CYL.RIGHT-1 & LEFT-1 Right and Left Brake Master Cylinders to the WD-01206-1 Rudder Pedals and WD-1211-L & -R Brake Pedal Torque Tubes as shown in Figure 4.

Step 6: Slide the WD-1209 Brake Pedals over the WD-1211-L & -R Brake Pedal Torque Tubes and against the WD-01206-1 Rudder Pedals as shown in Figure 4. Use a square to make sure both the WD-1209 and WD-01206-1 are vertical (or perpendicular to the work surface), then clamp the brake pedals to the rudder pedals as shown.



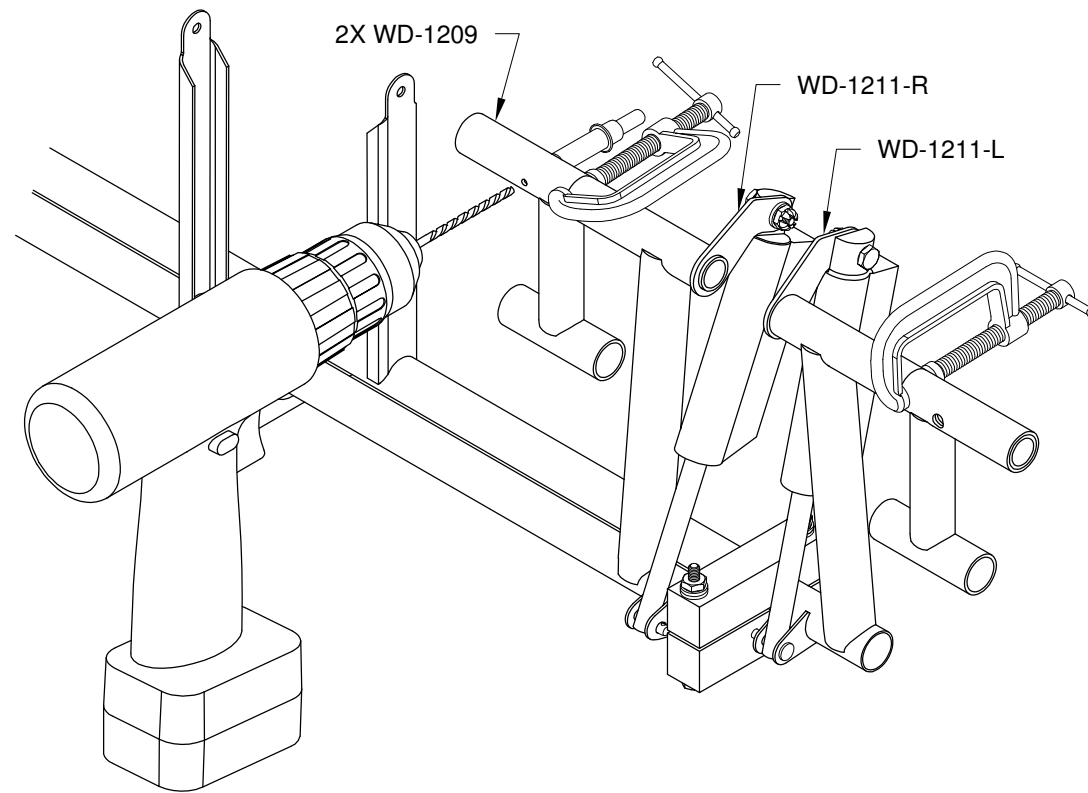
**FIGURE 4: ATTACHING THE MASTER CYLINDERS**



Step 1: There are 1/8 inch holes in both sides of the WD-1209 Brake Pedals. Match-Drill #30 the hole in one side of both brake pedals into the underlying WD-1211-L & -R Brake Pedal Torque Tubes. Cleco, then match-drill the hole in the other side.

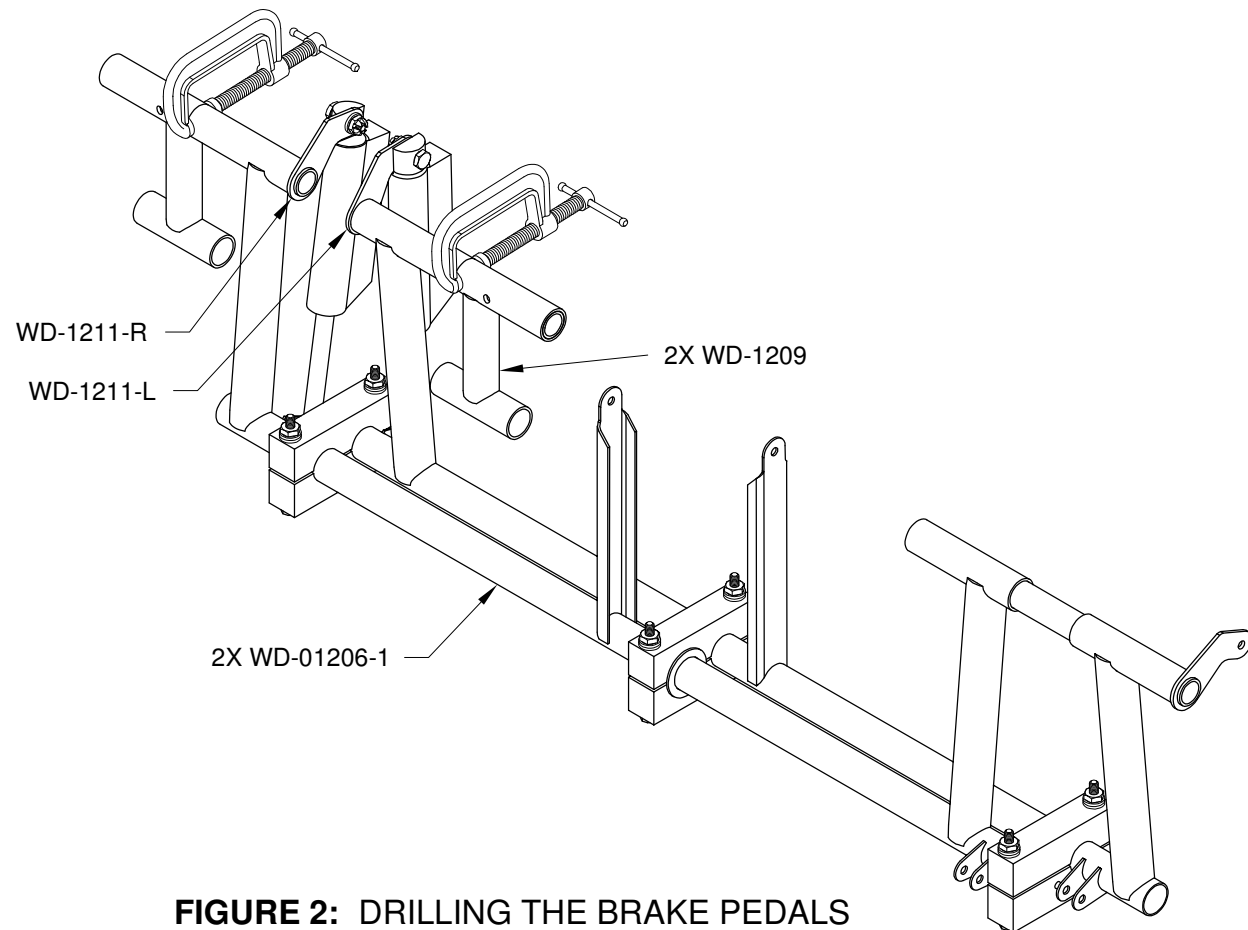
Step 2: Drill #12 all the way through the holes in both sides of the WD-1209 Brake Pedals and WD-1211-L & -R Brake Pedal Torque Tubes, then final-drill 1/4 all the way through.

Step 3: Remove the WD-1209 Brake Pedals and WD-1211-L & -R Brake Pedal Torque Tubes. Mark the parts to be reinstalled in the same locations.



**FIGURE 1: DRILLING THE BRAKE PEDALS**

Step 4: Repeat the same process for match-drilling and final-drilling the WD-1209 Brake Pedals and WD-1211-L & -R Brake Pedal Torque Tubes for the other end of the WD-01206-1 Rudder Pedals. The parts are assembled as shown in Figure 2.

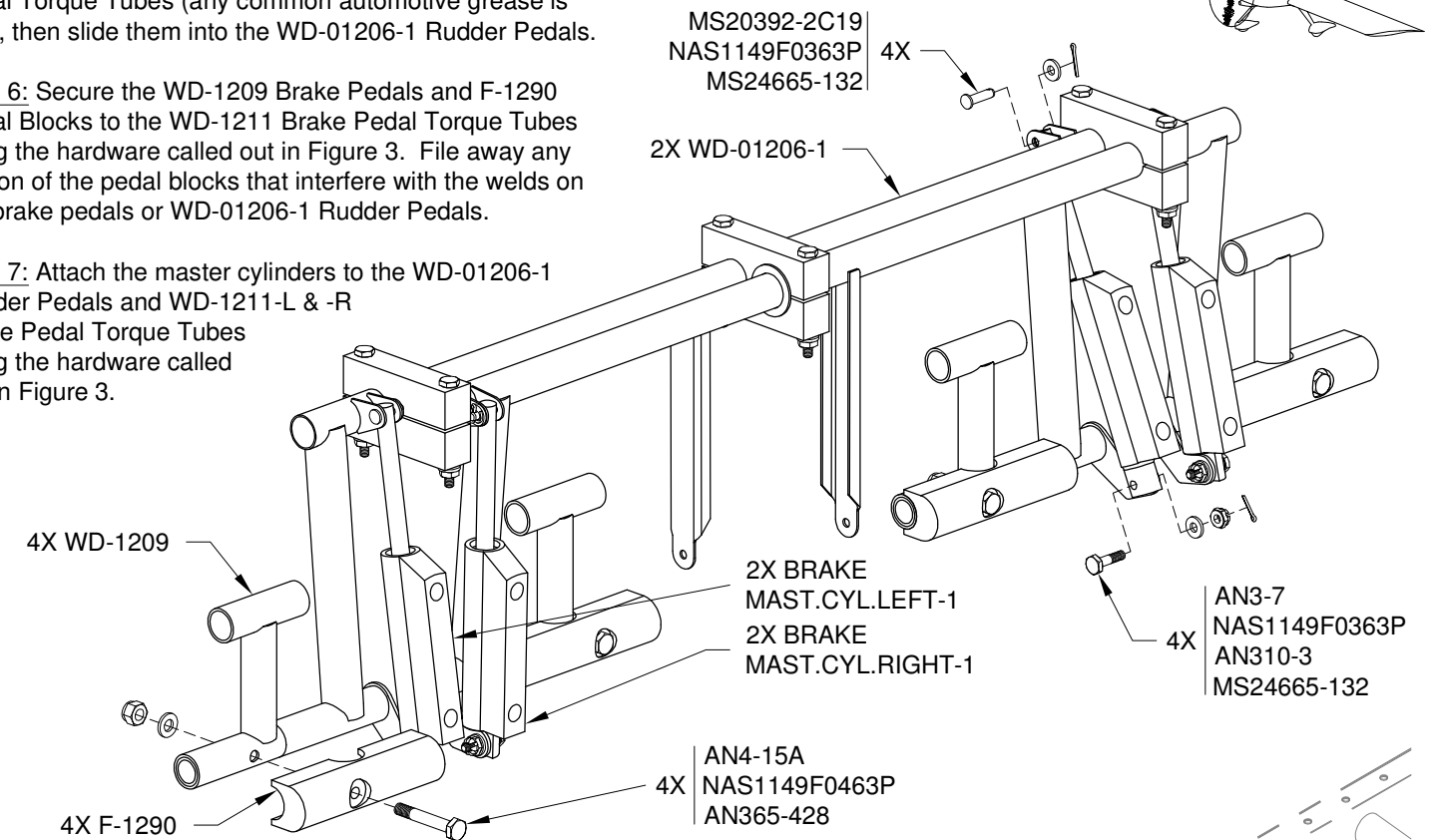


**FIGURE 2: DRILLING THE BRAKE PEDALS**

Step 5: Remove and grease the WD-1211-L & -R Brake Pedal Torque Tubes (any common automotive grease is fine), then slide them into the WD-01206-1 Rudder Pedals.

Step 6: Secure the WD-1209 Brake Pedals and F-1290 Pedal Blocks to the WD-1211 Brake Pedal Torque Tubes using the hardware called out in Figure 3. File away any portion of the pedal blocks that interfere with the welds on the brake pedals or WD-01206-1 Rudder Pedals.

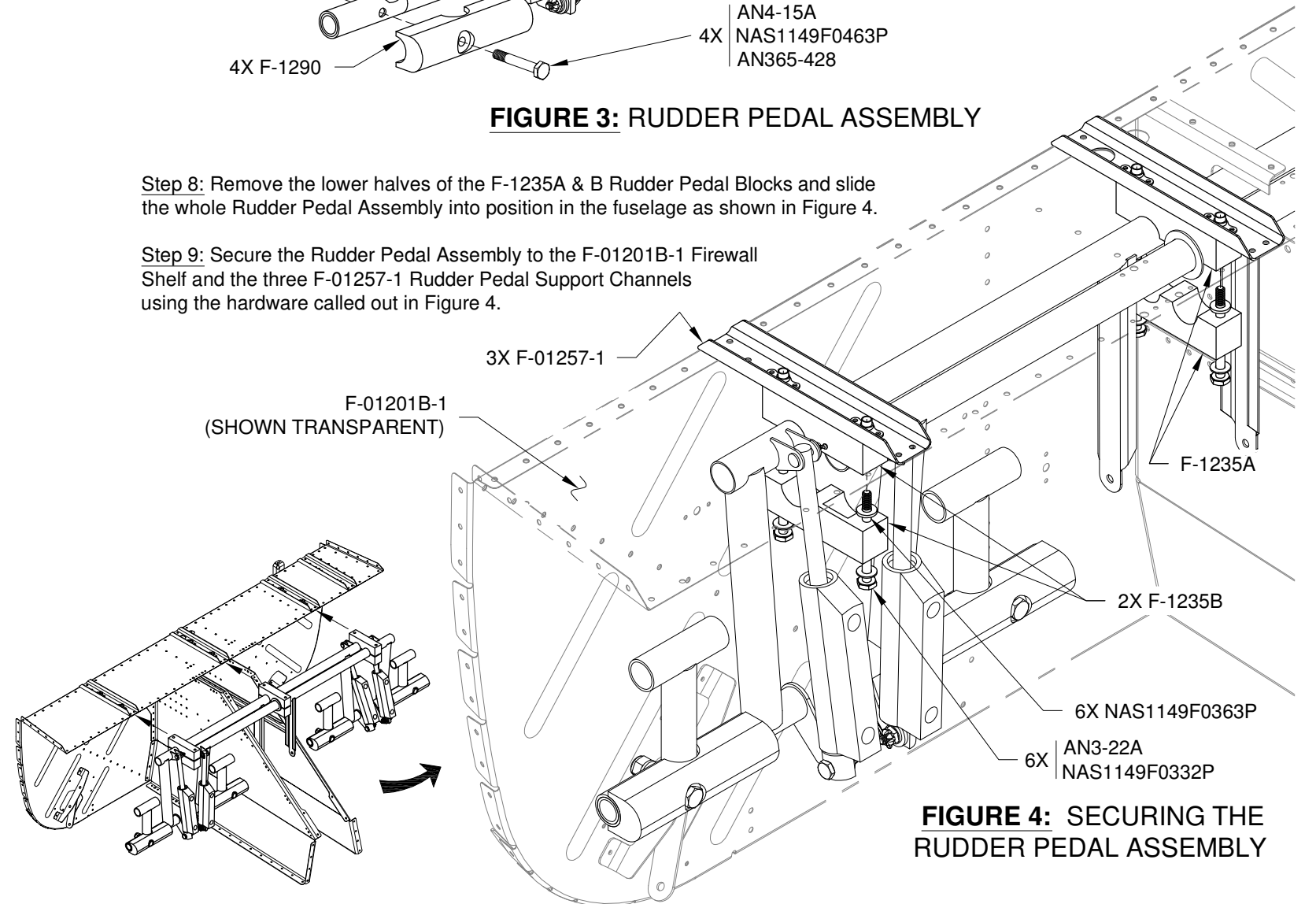
Step 7: Attach the master cylinders to the WD-01206-1 Rudder Pedals and WD-1211-L & -R Brake Pedal Torque Tubes using the hardware called out in Figure 3.



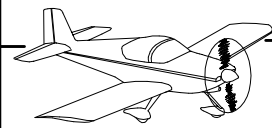
**FIGURE 3: RUDDER PEDAL ASSEMBLY**

Step 8: Remove the lower halves of the F-1235A & B Rudder Pedal Blocks and slide the whole Rudder Pedal Assembly into position in the fuselage as shown in Figure 4.

Step 9: Secure the Rudder Pedal Assembly to the F-01201B-1 Firewall Shelf and the three F-01257-1 Rudder Pedal Support Channels using the hardware called out in Figure 4.



**FIGURE 4: SECURING THE RUDDER PEDAL ASSEMBLY**

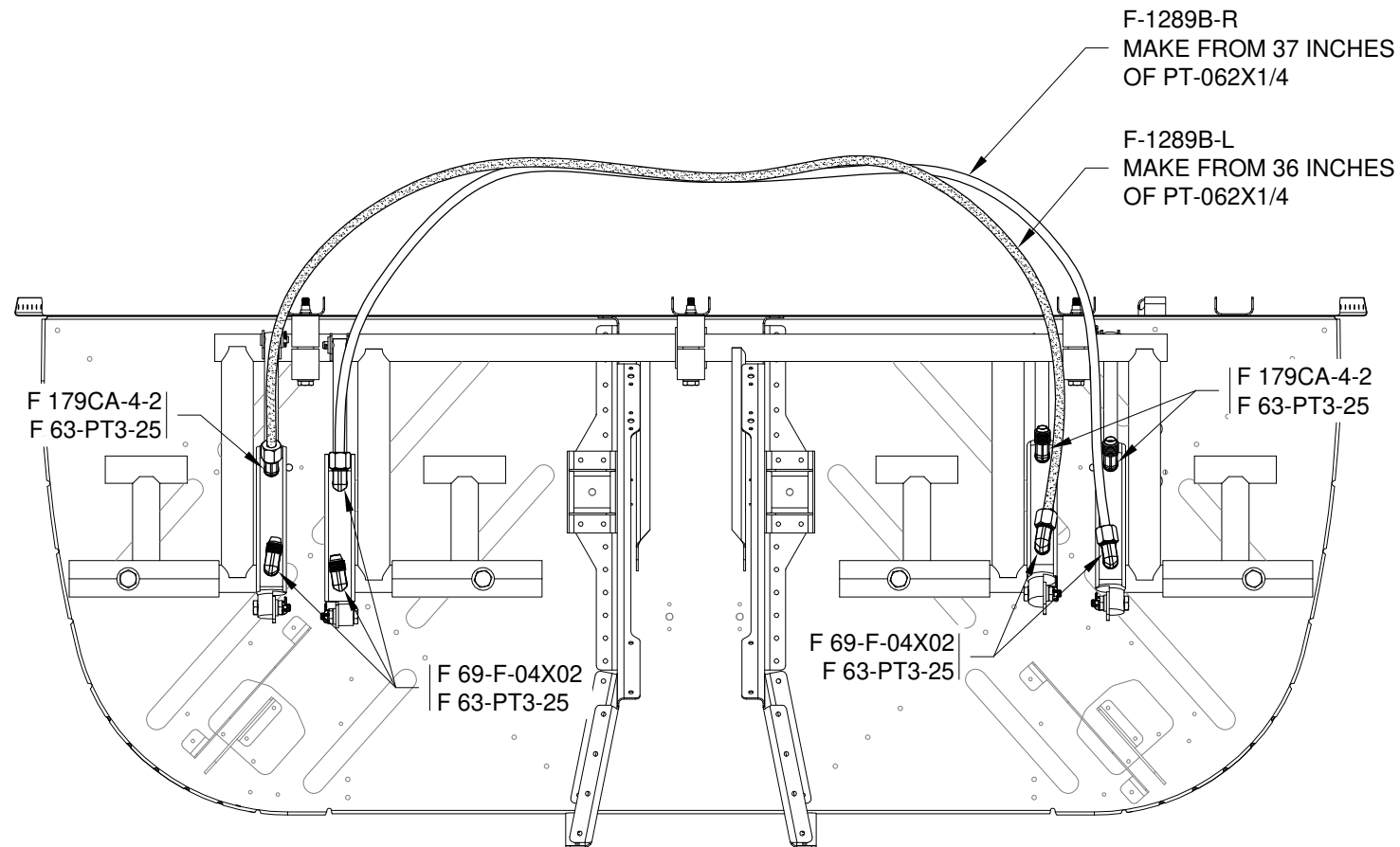


**NOTE:** The brake lines in this section are assembled with two different end fittings, the F 69-F-04x02 Brass Elbow and the F 179CA-4-2 Brass 45° Elbow. The main difference between the two assemblies is that the nut supplied with the brass 45° elbow has the sleeve attached to it.

**NOTE:** When directed to assemble the brake lines in this section, use the instructions of Section 5.22.

**Step 1:** Thread the brass elbows, called out in Figure 1, into the ports of the master cylinders as shown (use a small amount of pipe thread sealant on the threads). Note that the elbows in the lower ports are clocked to direct their corresponding brake lines between the elbows in the upper ports. The elbows in the upper ports are directed upward.

**Step 2:** Assemble the F-1289B-L & -R Cross-Over Brake Lines and connect them to their corresponding elbows as shown in Figure 1.



**FIGURE 1: CROSS-OVER BRAKE LINES**

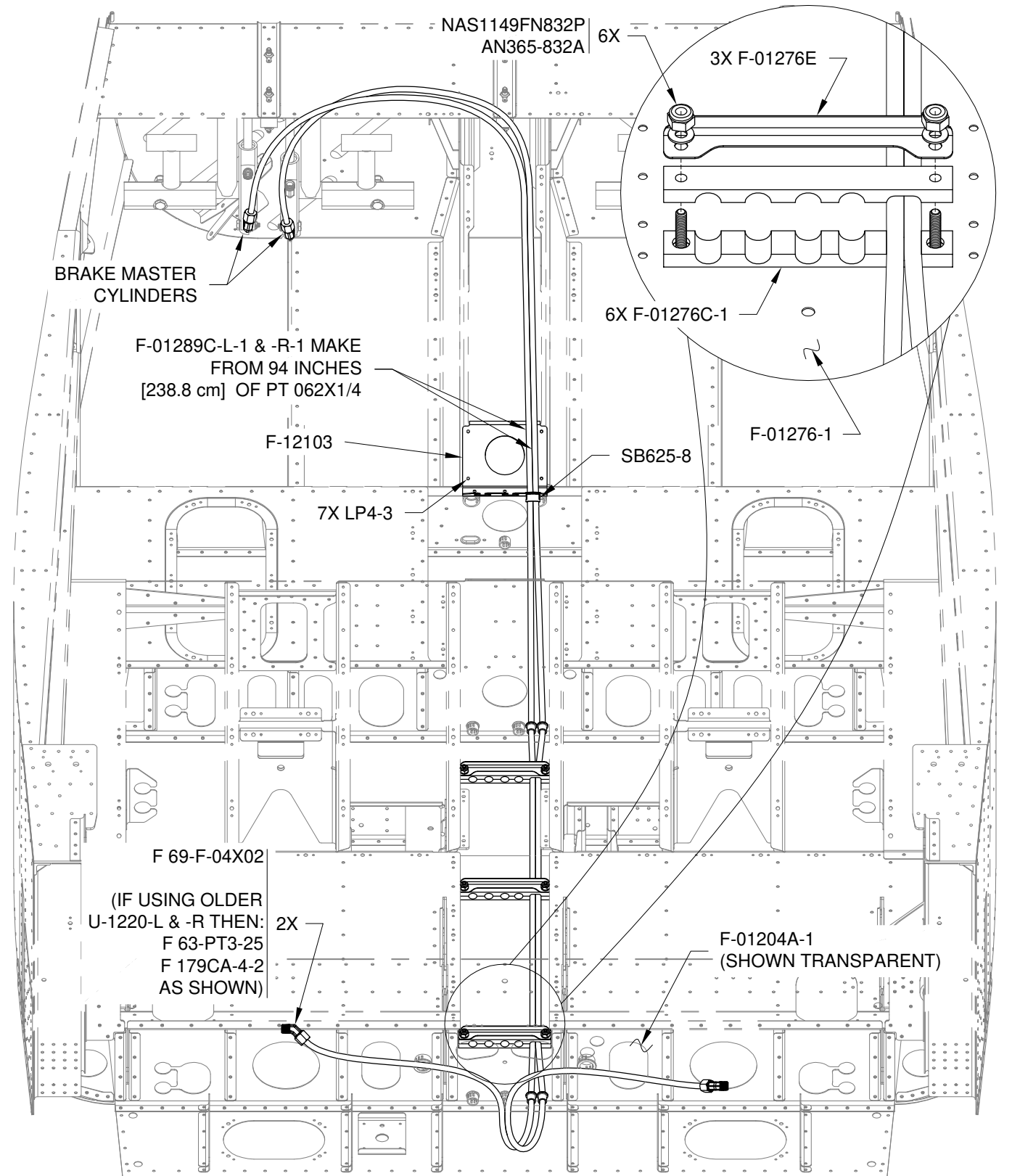
**Step 3:** Rivet the F-12103 Tunnel Brace to the fuselage tunnel as shown in Figure 2.

**Step 4:** Install a snap bushing in the right-most hole in the F-12103 Tunnel Brace flange as shown in Figure 2.

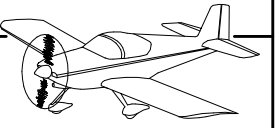
**Step 5:** Attach the F-01276C-1 Systems Blocks and F-01276E Systems Block Stiffeners to the screws in the F-01276-1 Bottom Skin as shown in the detail view of Figure 2.

**NOTE:** The aft end of the main brake lines are secured in Section 35iS Landing Gear & Engine Mount.

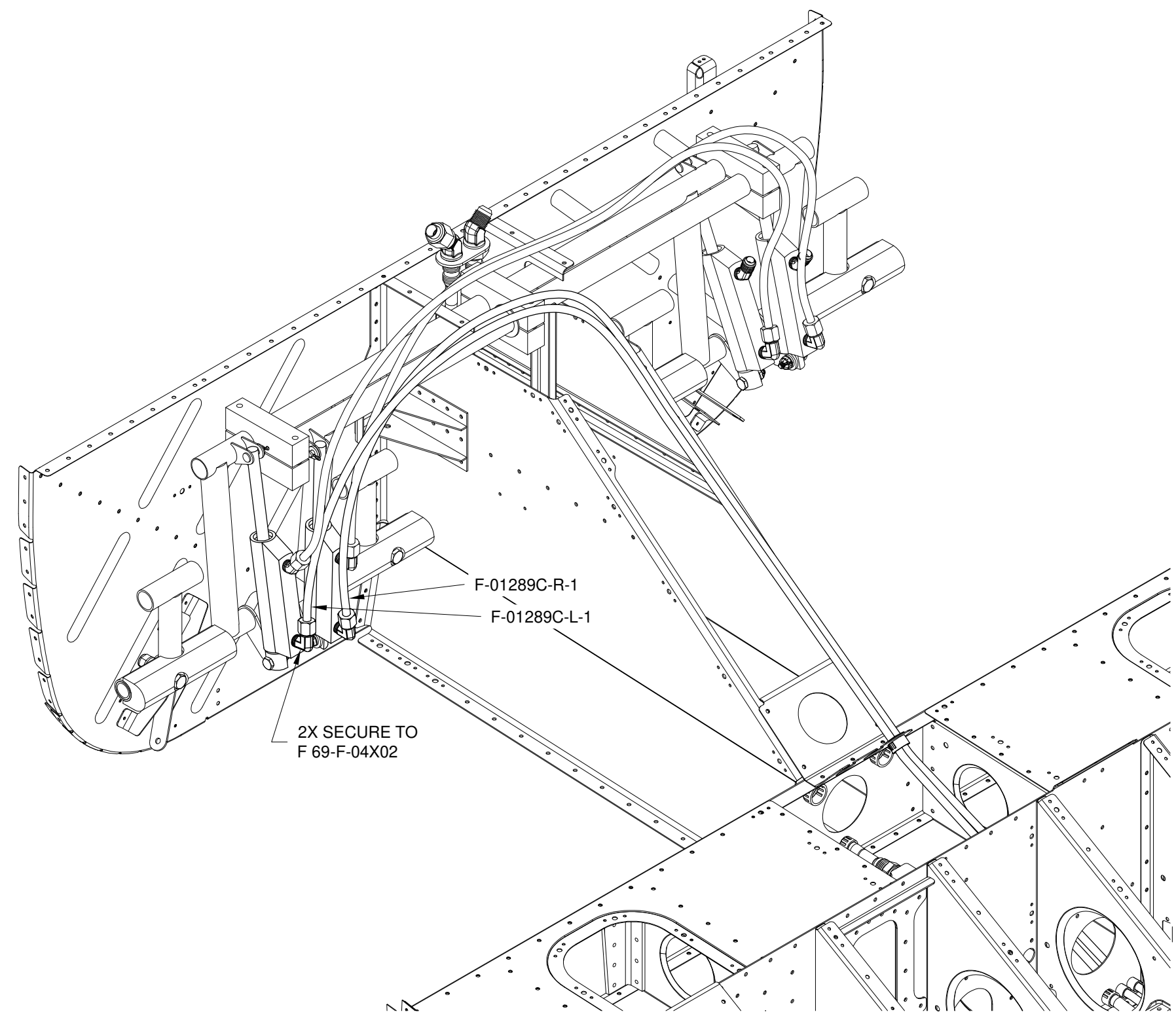
**Step 6:** As shown in Figure 2, the F-01289C-L-1 & -R-1 Main Brake Lines run from the F-01204A-1 Center Section Bulkhead to the brake master cylinders on the left side of the fuselage. Install the compression fittings (nut, sleeve, insert, and elbow) at the aft end of the main brake lines as shown. Route the main brake lines forward through the snap bushings and F-01276C-1 System Blocks to the left side master cylinders. Mark both ends of the left and right brake lines with an "L" or an "R", respectively.



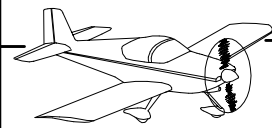
**FIGURE 2: INSTALLING SYSTEMS BLOCKS AND MAIN BRAKE LINES (TOP VIEW LOOKING FORWARD)**



Step 1: Secure the F-01289C-L-1 & -R-1 Main Brake Lines to the lower elbow of both left side master cylinders as shown in Figure 1.

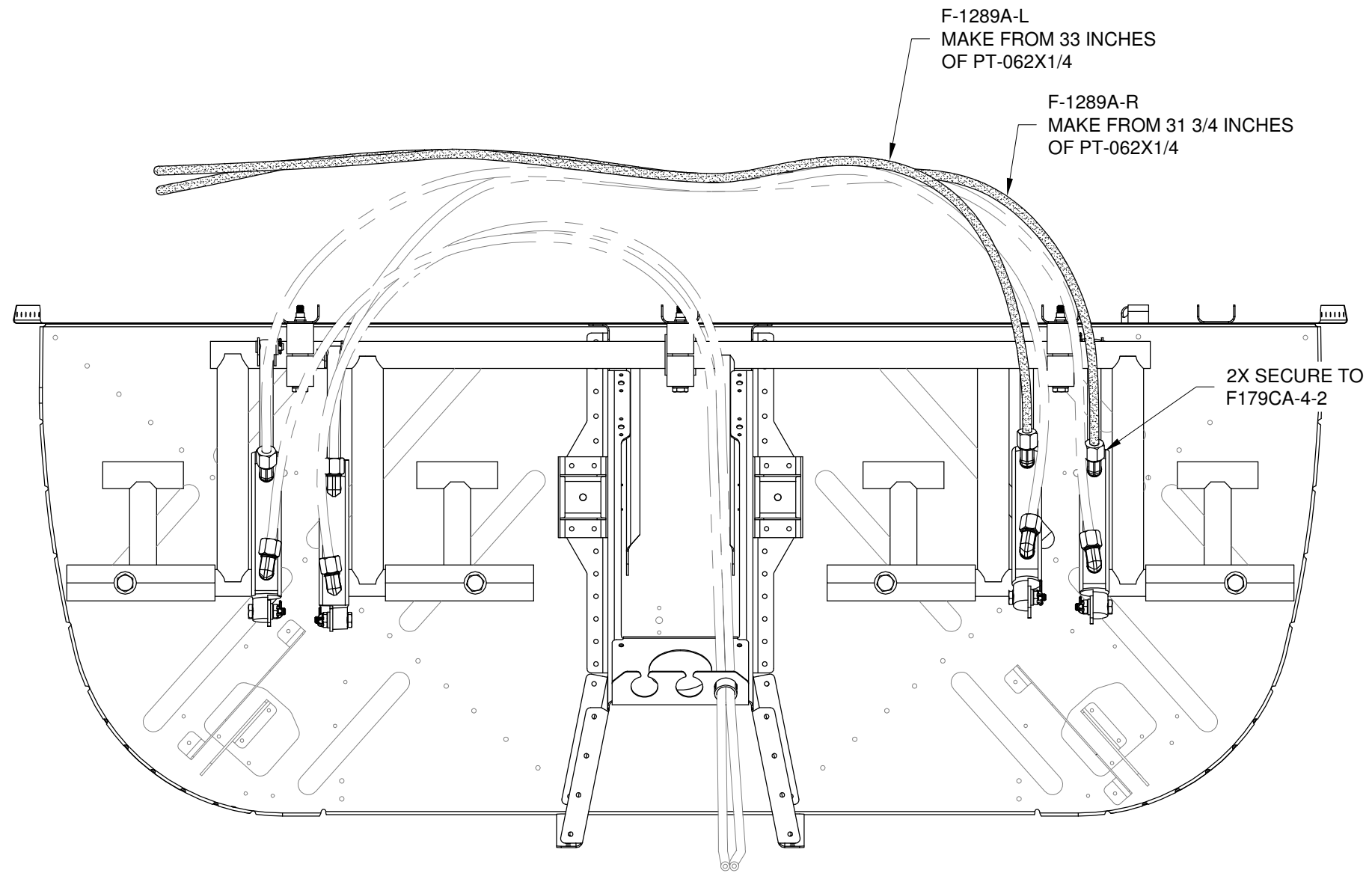


**FIGURE 1: SECURING THE MAIN BRAKE LINES**



**NOTE:** The other end of the reservoir brake lines are secured to the brake reservoir in Section 32iS Flight Controls.

Step 1: Secure the F-1289A-L & -R Reservoir Brake Lines to the upper elbow of both right side master cylinders as shown in Figure 1.



F-1289A-L  
MAKE FROM 33 INCHES  
OF PT-062X1/4

F-1289A-R  
MAKE FROM 31 3/4 INCHES  
OF PT-062X1/4

2X SECURE TO  
F179CA-4-2

**FIGURE 1:** RESERVOIR BRAKE LINES

