

SECTION 18: FLAPERON

Step 1: Make the A-1207-L Actuation Bracket from AA6-125 x 1 1/2 x 2 x 10 as shown in Figure 1.

Make the A-1207-R Actuation Bracket which is the opposite of the A-1207-L Actuation Bracket.

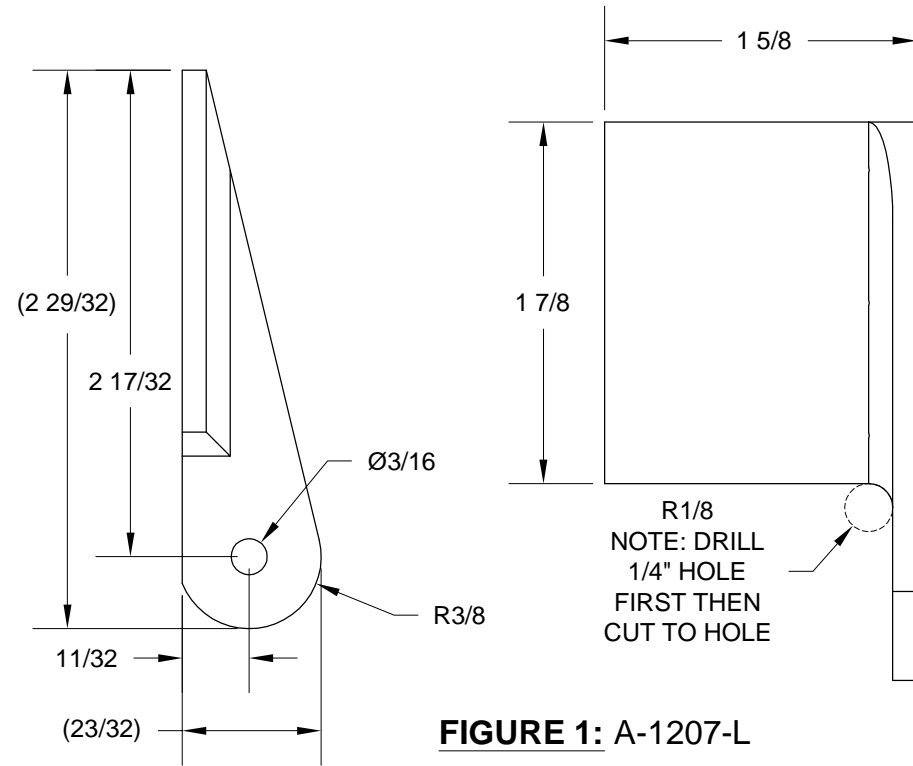


FIGURE 1: A-1207-L

Step 2: Make four A-1206 Pivot Brackets from AEX Tie Down as shown in Figure 2.

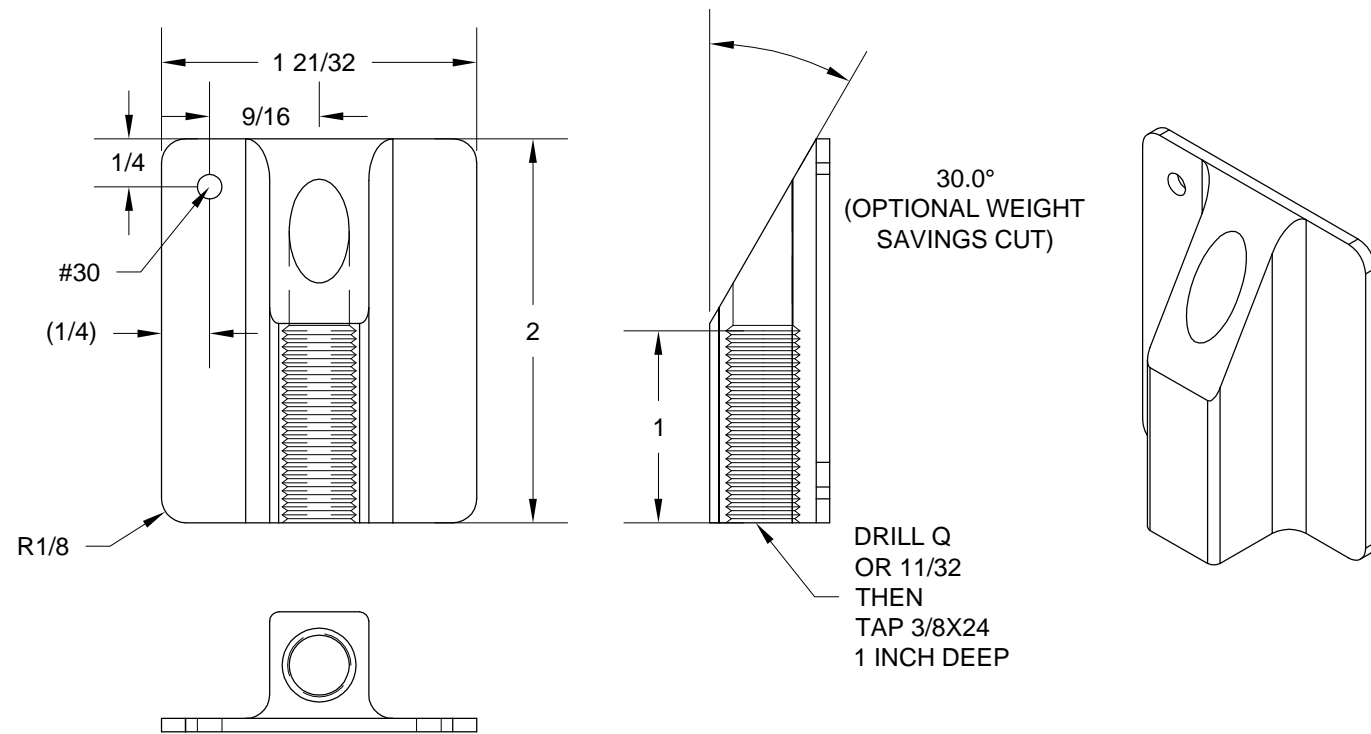
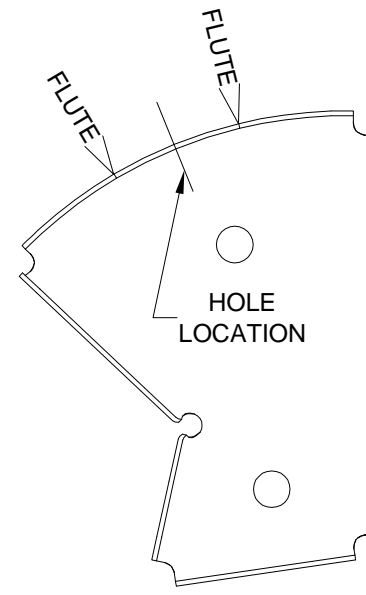


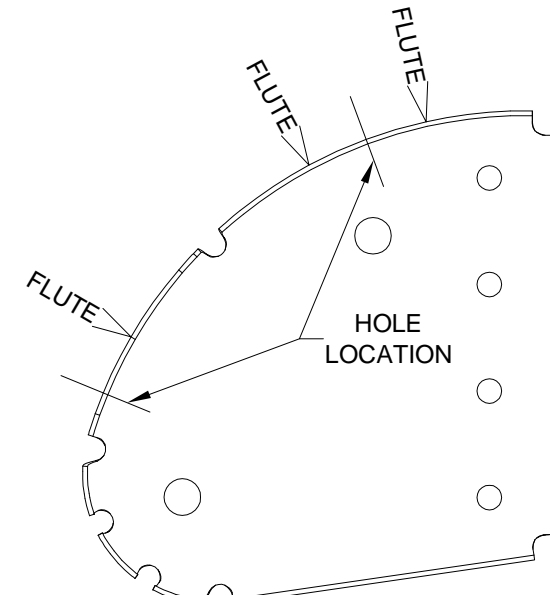
FIGURE 2: A-1206

Step 3: Flute the flanges of the A-1204-L & -R Outbd Nose Ribs and A-1210-L & -R Inbd Nose Ribs at the locations shown in Figures 3 and 4.

Flute the rib flanges so as to make the rib webs as straight as possible however it is not absolutely necessary for the ribs to be perfectly straight.

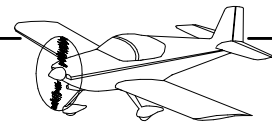


**FIGURE 3:
A-1204 FLUTING LOCATIONS**



**FIGURE 4:
A-1210 FLUTING LOCATIONS**

NOTE: The remainder of this section describes the assembly of the left flaperon. The right flaperon is a mirror of the left. For each step describing the assembly of the left, also complete the same operations for the right.



Step 1: Cleco together the A-1203 Spar, A-1204-L & -R Outbd Nose Ribs, A-909 Aileron Counterbalance, and A-1201C-L Outbd Nose Skin as shown in Figure 1.

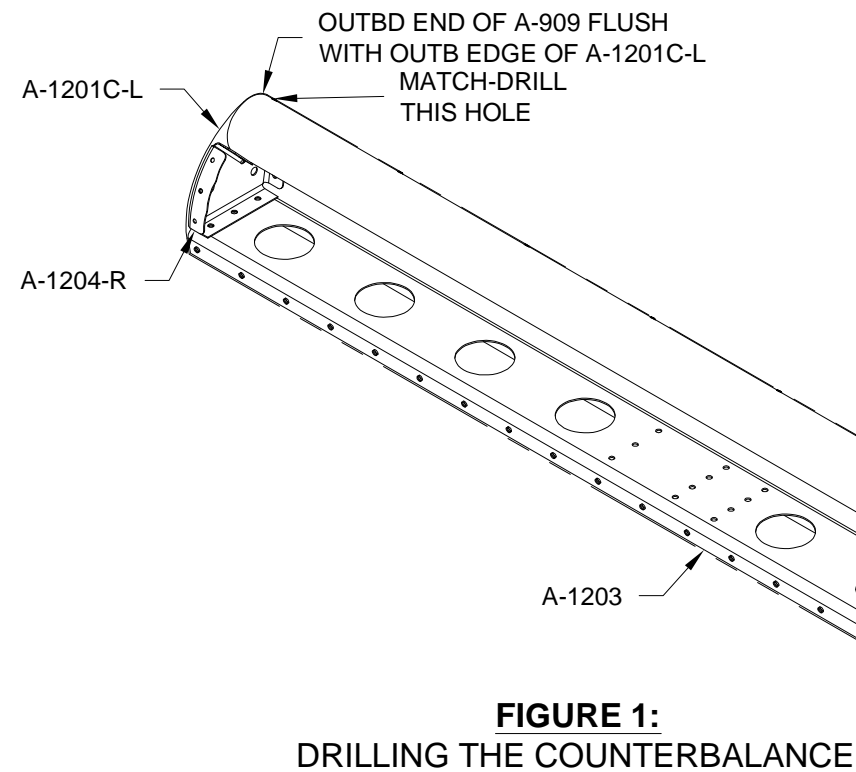


FIGURE 1:
DRILLING THE COUNTERBALANCE

Step 2: Match-Drill #30 the most outboard hole and most inboard hole of the A-1201C-L Outbd Nose Skin into the A-909 Aileron Counterbalance. See "match-drill" call-outs in Figure 1.

Step 3: Un-cleco all the parts. Deburr the two holes just drilled into the A-909 Aileron Counterbalance. Rivet the A-1204-L & -R Outbd Nose Ribs to the aileron counterbalance as shown in Figure 2.

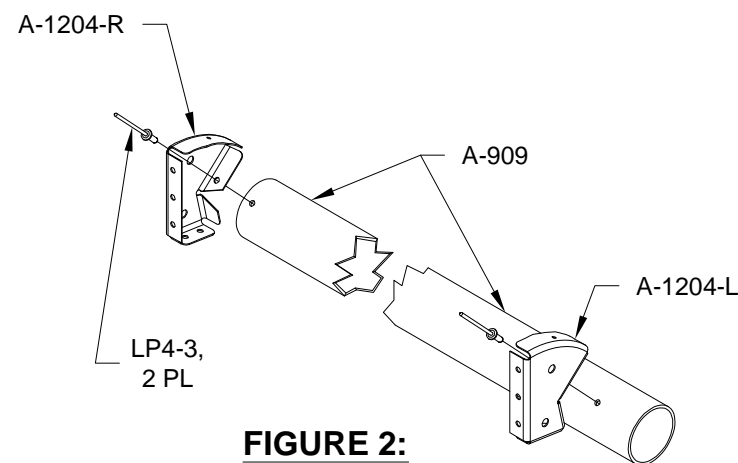


FIGURE 2:
RIVETING THE OUTBD NOSE RIBS
TO THE COUNTERBALANCE

Step 4: Cleco the A-1204-L & -R Outbd Nose Ribs/A-909 Aileron Counterbalance subassembly to the A-1203 Spar. Cleco the A-1201C-L Outbd Nose Skin to the spar and outbd nose ribs. See Figure 3.

Step 5: Match-Drill #30 the holes of the A-1201C-L Outbd Nose Skin into the A-909 Aileron Counterbalance. See "match-drill" call-outs in Figure 3.

Match-Drill #30 the holes of the outbd nose skin into the upper flanges of the A-1204-L & -R Outbd Nose Ribs. See "match-drill" call-outs in Figure 3.

Remove the #40 cleco holding the outbd nose skin to the upper flange of each outbd nose rib and final-drill #30. See "final-drill" call-outs in Figure 3.

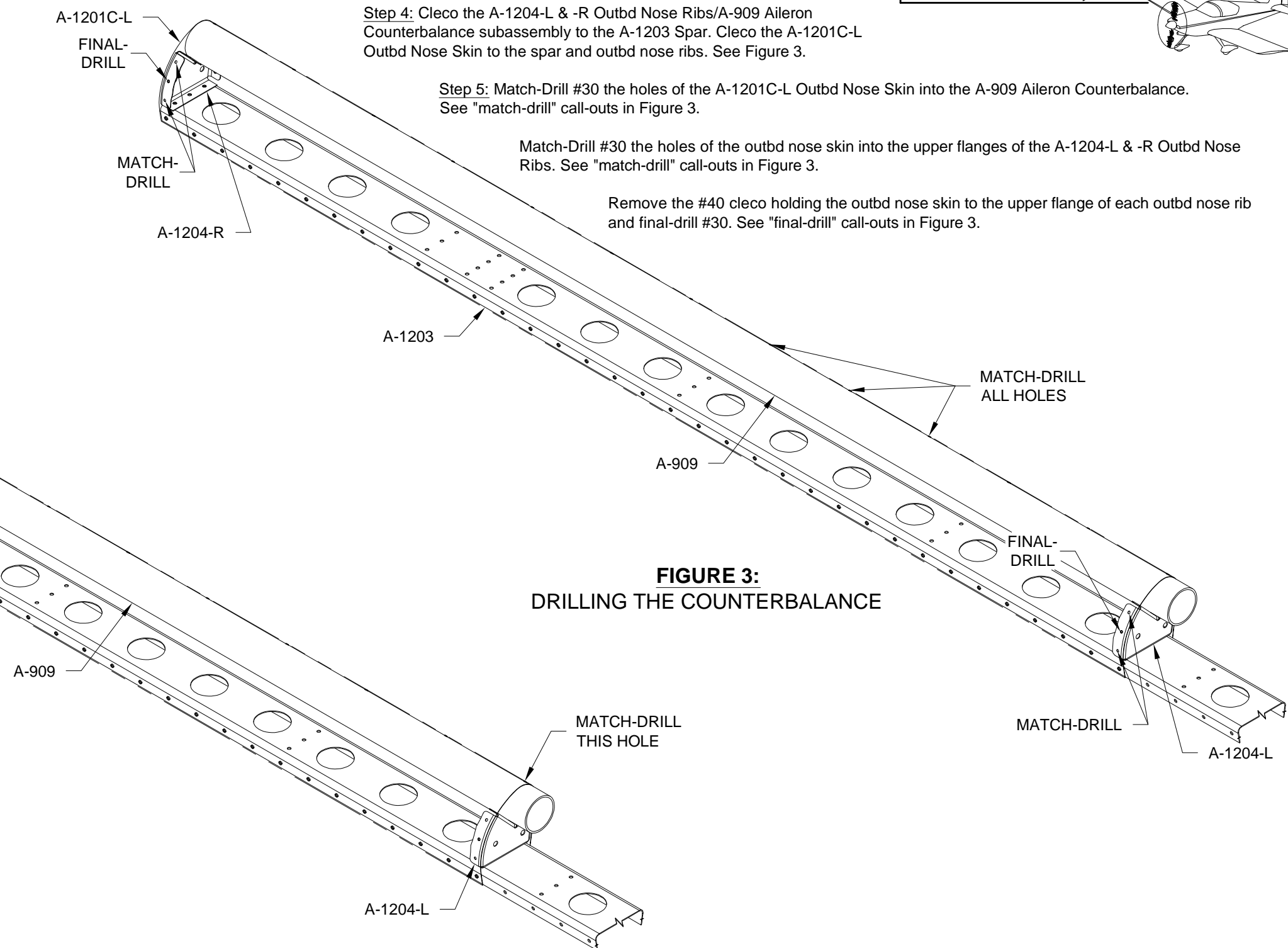
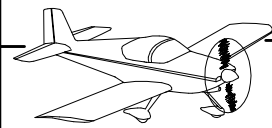


FIGURE 3:
DRILLING THE COUNTERBALANCE

Step 6: Un-cleco all parts. Deburr all holes in the A-909 Aileron Counterbalance and all holes in the A-1204-L & -R Outbd Nose Ribs and A-1201C-L Outbd Nose Skin that were either match-drilled or final drilled.



Step 1: Break apart the A-1208 Brackets by removing the hatched areas shown in Figure 1.

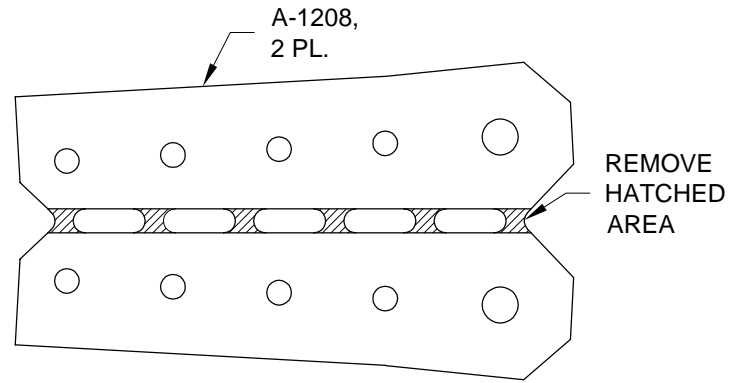
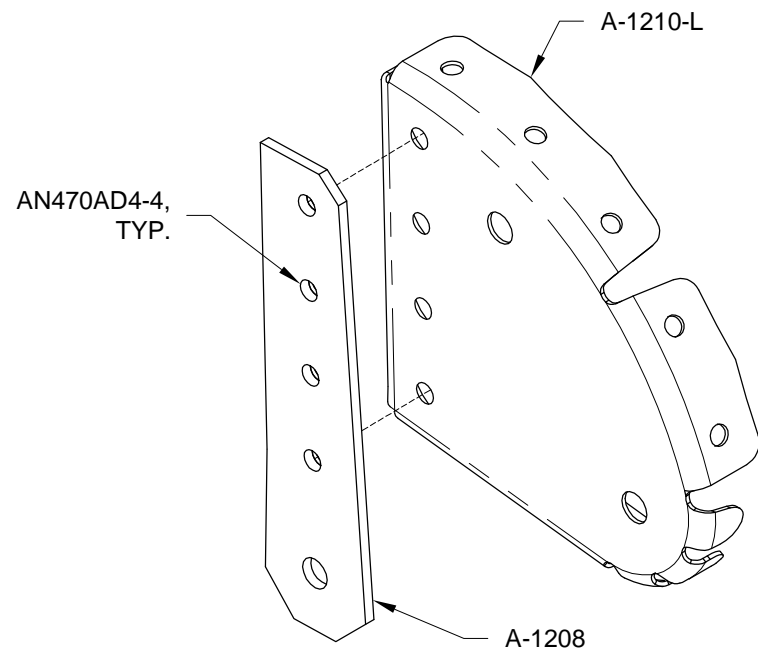


FIGURE 1: SEPARATING BRACKETS

Step 2: Deburr the edges of the A-1210-L Inbd Nose Rib. Cleco the A-1208 Bracket to the inbd nose rib as shown in Figure 2.

Step 3: Rivet the A-1208 Bracket to the A-1210-L Inbd Nose Rib per the callouts in Figure 2.



**FIGURE 2:
INBD NOSE RIB & BRACKET ASSEMBLY**

Step 4: Cleco two A-1206 Pivot Brackets and the Inbd Nose Rib & Bracket Assembly to the A-1203 Spar as shown in Figure 3.

Step 5: Insert an AN3 Bolt through the hole in the A-1208 Bracket and A-1207-L Actuation Bracket. Use washers to space the parts as shown in Figure 3.

Step 6: Align the sides of the A-1207-L Actuation Bracket and A-1206 Pivot Brackets perpendicular with the upper edge of the A-1203 Spar. Match-Drill #30 the holes in the spar into the actuation bracket and pivot brackets. Cleco as you drill.

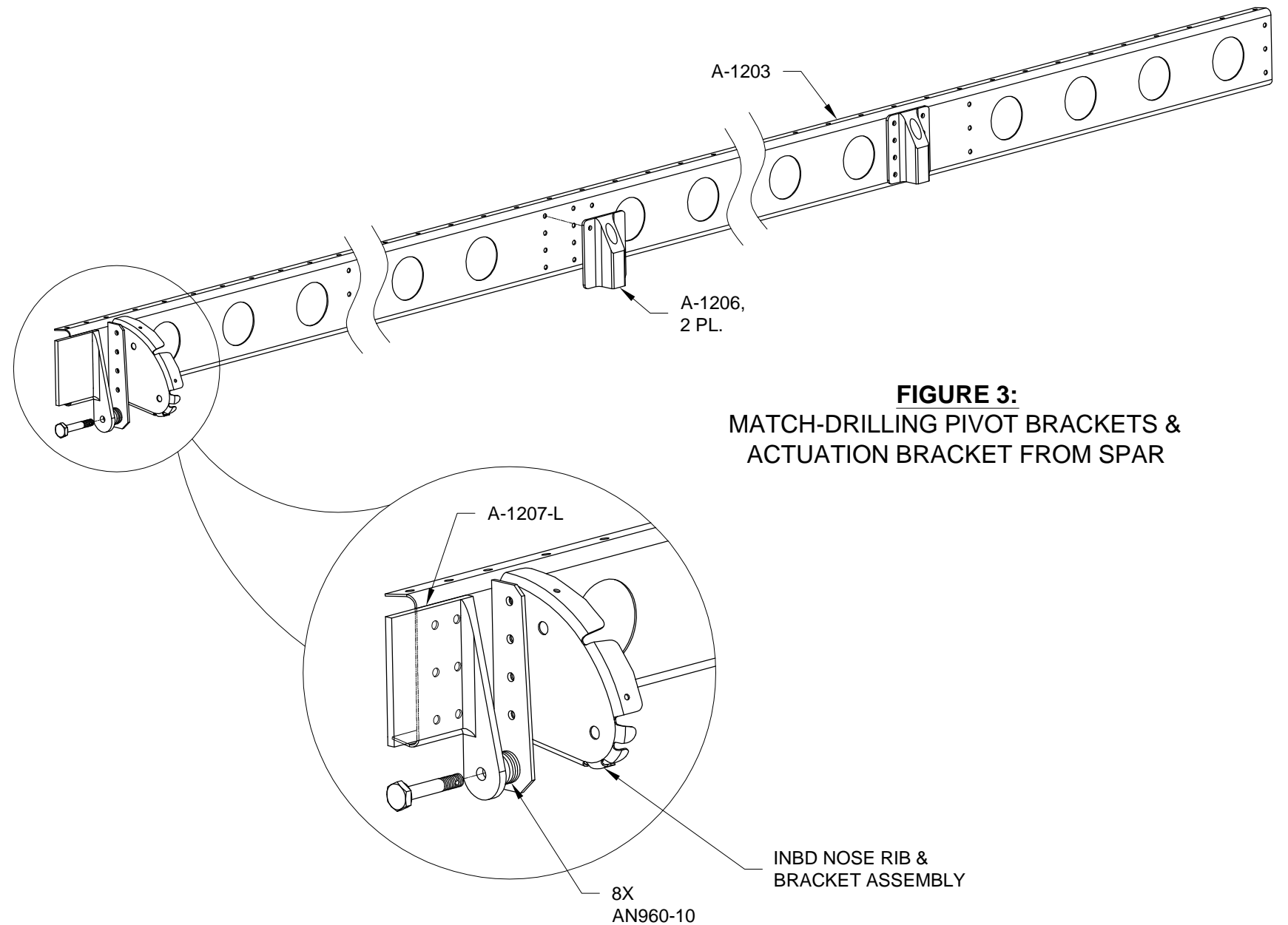
Step 7: Remove the A-1206 Pivot Brackets, A-1207-L Actuation Bracket, and Inbd Nose Rib & Bracket Assembly from the A-1203 Spar and deburr all holes in all parts that were match-drilled.

Step 8: Inspect the outside edges of all A-1204 Outbd Nose Ribs, and A-1205 Main Ribs, and deburr any edges that are left sharp from the manufacturing process and may scratch the mating skins or spar during final assembly.

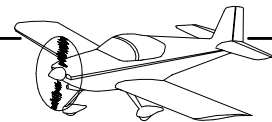
Deburr the inboard and outboard edges of the A-1202A & A-1202B Inbd & Outbd Flaperon Skins.

Deburr the aft edges, upper and lower, of the A-1201A, A-1201B, & A-1201C Inbd, Mid, & Outbd Nose Skins.

Prime the A-1206 Pivot Brackets and A-1207-L & -R Actuation Brackets. If desired, all other flaperon parts may be primed at this time.



**FIGURE 3:
MATCH-DRILLING PIVOT BRACKETS &
ACTUATION BRACKET FROM SPAR**



Step 1: Rivet the A-1207-L Actuation Bracket (outboard row of rivets only), A-1206 Pivot Brackets and A-1203 Spar together per the callouts in Figure 1.

Step 2: Cleco ten of 12 A-1205 Main Ribs to the A-1203 Spar. Leave the 5th rib from the inboard end and the most outboard main rib un-clecoed. Rivet the main ribs to the spar using the rivets called-out in Figure 1.

Step 3: Cleco the Inbd Nose Rib & Bracket Assembly, A-1210-R Inbd Nose Rib, the remaining two A-1205 Main Ribs, and the A-909/A-1204-L & -R Outbd Nose Rib/Counterbalance Assembly to the A-1203 Spar. See Figure 1.

Step 4: Rivet all the parts assembled in Step 2 together per the callouts in Figure 1.

INSTALL RIVETS AT THIS LOCATION WITH HEADS ON A-1205. FLEX OUT OF PLACE TO ALLOW CLEARANCE FOR RIVETING TOOL

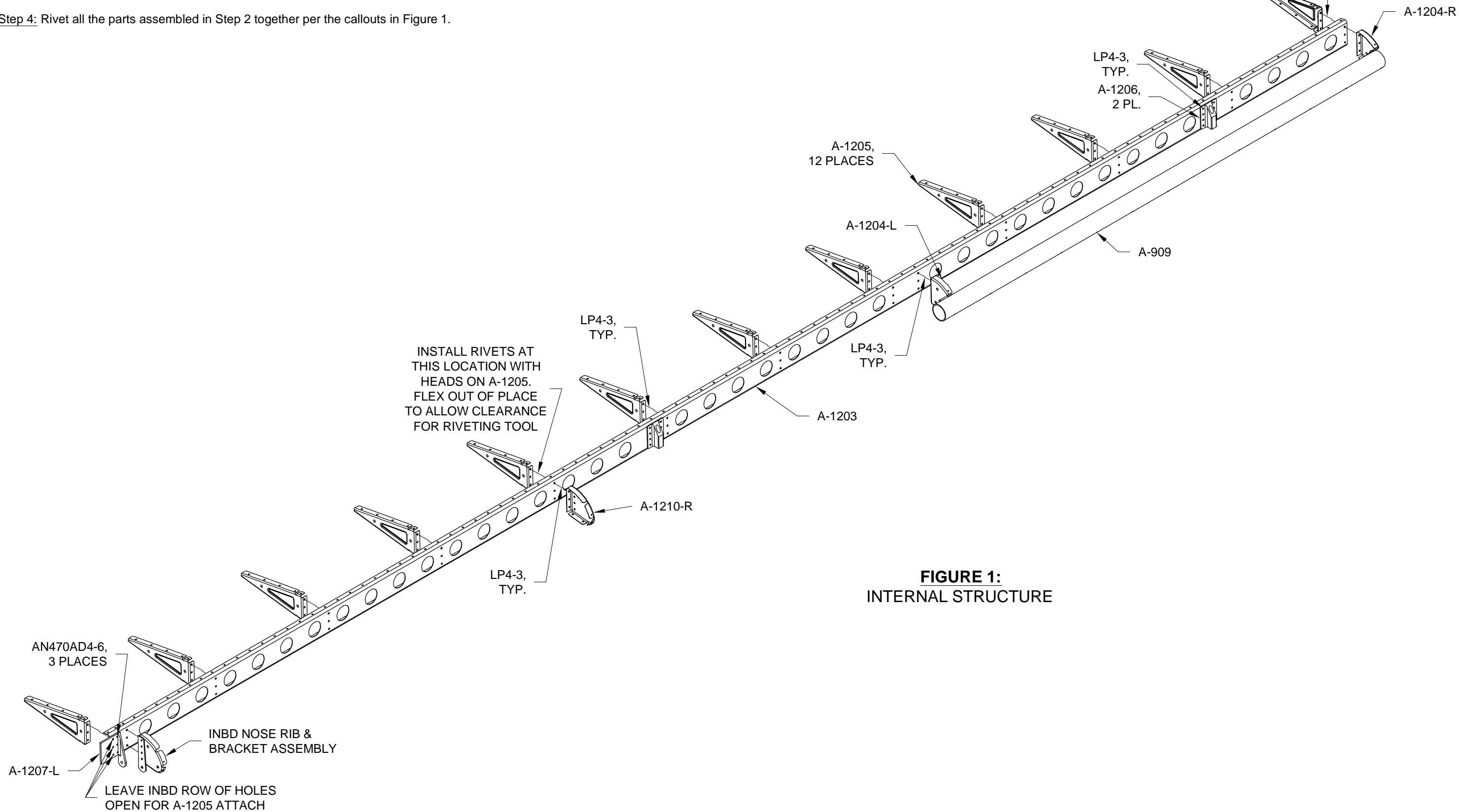
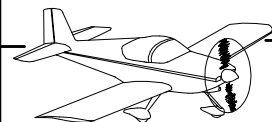


FIGURE 1:
INTERNAL STRUCTURE



Step 1: Cleco the A-1202B Outbd Flaperon Skin and A-1202A-L Inbd Flaperon Skin to the A-1205 Main Ribs and A-1203 Spar. Check that the inbd and outbd flaperon skins are bent properly as shown in Figure 2. If not, work the inbd and outbd flaperon skins by hand until they lie flat against the main ribs.

Step 2: When satisfied with the fit of the A-1202B Outbd Flaperon Skin and A-1202A-L Inbd Flaperon Skin, rivet the outbd flaperon skin and inbd flaperon skin to the A-1205 Main Ribs and to each other as shown in Figure 1.

Step 3: Cleco the A-1201C-L Outbd Nose Skin to the under structure as shown in Figure 1. Rivet the outbd nose skin to the under structure EXCEPT along its inboard edge where the A-1201B-L Mid Nose Skin overlaps as shown in Figure 1.

Step 4: Cleco the A-1201A-L Inbd Nose Skin to the under structure as shown in Figure 1. Match-Drill #30 the holes common between the inbd nose skin and the A-1210-L & -R Inbd Nose Ribs. Insert a cleco after each hole is drilled. Remove the #40 clecos from each inbd nose rib and final-drill #30.

Step 5: Remove the A-1201A-L Inbd Nose Skin and deburr all match-drilled holes.

Cleco the A-1201A-L Inbd Nose Skin and the A-1201B-L Mid Nose Skin to the under structure as shown in Figure 1. Rivet the inbd and mid nose skins to the under structure using the rivets called-out in Figure 1.

Step 6: The mid and outboard flaperon hinge points use rod-end bearings threaded into the A-1206 Pivot Brackets as shown in Figure 2.

Apply a thin film of Loctite 243 to the first third of the threads of each rod-end bearing before installation into the pivot bracket. Wipe-off any Loctite that is visible after installing the rod-end bearings.

Place the flaperon on a horizontal surface with rod-end bearings pointing up and allow the Loctite to cure for approximately 24 hours.

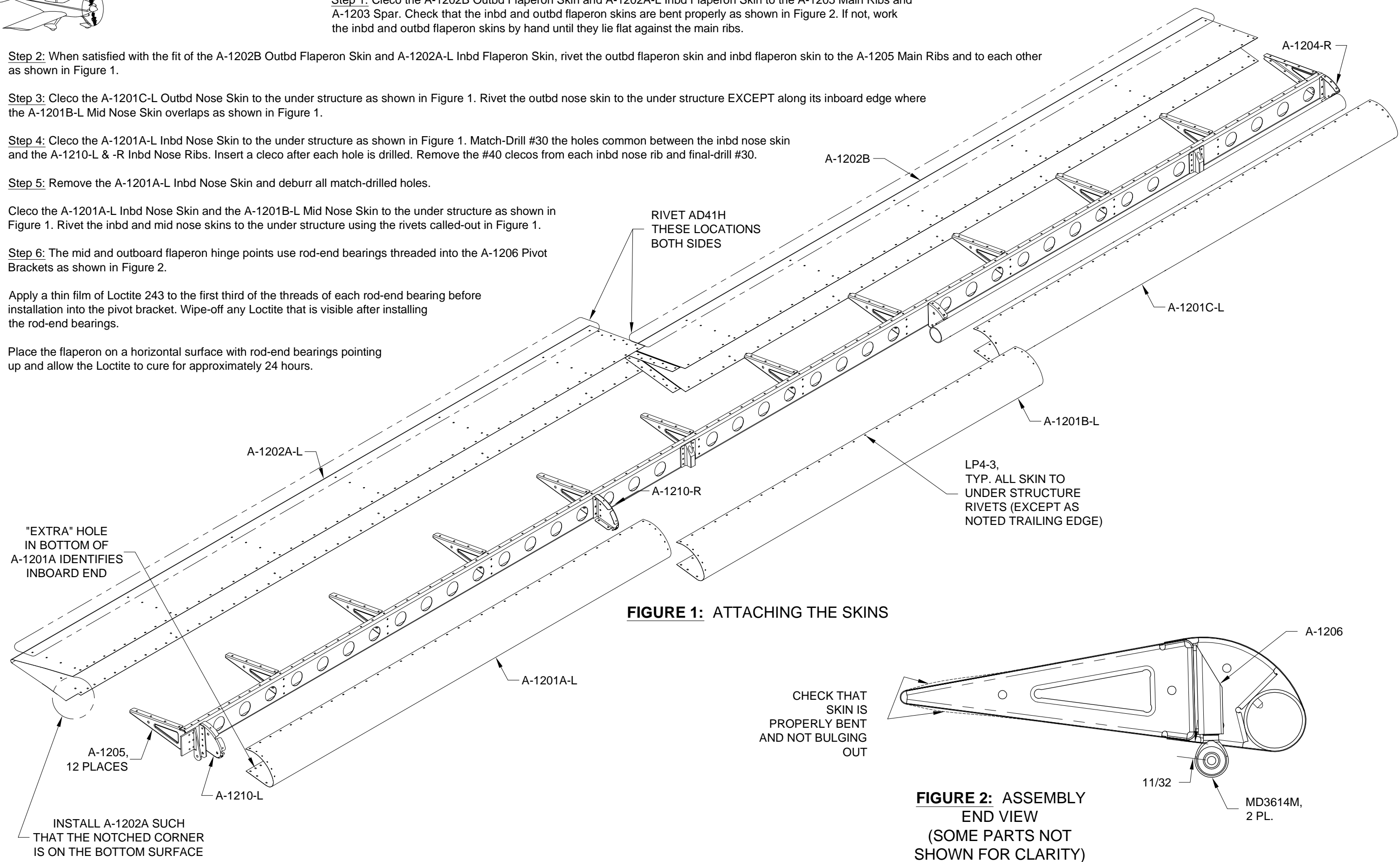


FIGURE 1: ATTACHING THE SKINS

CHECK THAT SKIN IS PROPERLY BENT AND NOT BULGING OUT

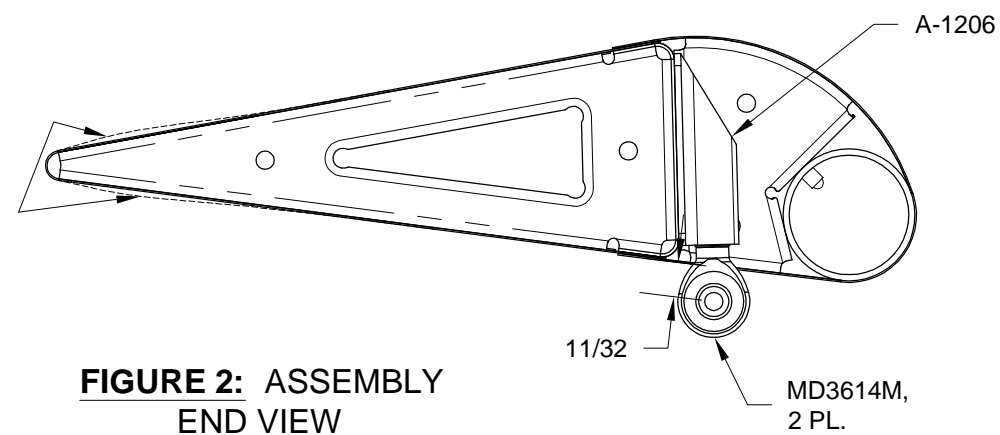


FIGURE 2: ASSEMBLY END VIEW (SOME PARTS NOT SHOWN FOR CLARITY)